



STANDARD

ANSI/ASHRAE Standard 52.2-2017

(Supersedes ANSI/ASHRAE Standard 52.2-2012)

Includes ANSI/ASHRAE addenda listed in Appendix H

Method of Testing General Ventilation Air-Cleaning Devices for Removal Efficiency by Particle Size

See Informative Appendix H for approval dates by the ASHRAE Standards Committee, the ASHRAE Technology Committee, and the American National Standards Institute.

This Standard is under continuous maintenance by a Standing Standard Project Committee (SSPC) for which the Standards Committee has established a documented program for regular publication of addenda or revisions, including procedures for timely, documented, consensus action on requests for change to any part of the Standard. The change submittal form, instructions, and deadlines may be obtained in electronic form from the ASHRAE website (www.ashrae.org) or in paper form from the Senior Manager of Standards. The latest edition of an ASHRAE Standard may be purchased from the ASHRAE website (www.ashrae.org) or from ASHRAE Customer Service, 1791 Tullie Circle, NE, Atlanta, GA 30329-2305. E-mail: orders@ashrae.org. Fax: 678-539-2129. Telephone: 404-636-8400 (worldwide), or toll free 1-800-527-4723 (for orders in US and Canada). For reprint permission, go to www.ashrae.org/permissions.

© 2017 ASHRAE

ISSN 1041-2336



ASHRAE Standing Standard Project Committee 52.2
Cognizant TC: 2.4, Particulate Air Contaminants and Particulate Removal Equipment
SPLS Liaison: Rita M. Harrold

Michael D. Corbat*, *Chair*
Kathleen Owen*, *Vice-Chair*
Todd A. McGrath*, *Secretary*
Robert B. Burkhead*
Richard K. Chesson, Jr.*
Kyung-Ju Choi*

David. B. Christopher*
Jeron Downing*
Dara Marina Feddersen*
Chris Fischer*
Sanjeev K. Hingorani*
David Matier*

Phil Maybee*
Stephen W. Nicholas*
Christine Q. Sun*
Paolo M. Tronville*

* Denotes members of voting status when the document was approved for publication

ASHRAE STANDARDS COMMITTEE 2016–2017

Rita M. Harrold, *Chair*
Steven J. Emmerich, *Vice-Chair*
James D. Aswegan
Niels Bidstrup
Donald M. Brundage
Drury B. Crawley
John F. Dunlap,
James W. Earley, Jr.
Keith I. Emerson
Julie M. Ferguson

Michael W. Gallagher
Walter T. Grondzik
Vinod P. Gupta
Susanna S. Hanson
Roger L. Hedrick
Rick M. Heiden
Srinivas Katipamula
Cesar L. Lim
Arsen K. Melikov
R. Lee Millies, Jr.

Cyrus H. Nasseri
David Robin
Peter Simmonds
Dennis A. Stanke
Wayne H. Stoppelmoor, Jr.
Jack H. Zarour
William F. Walter, *BOD ExO*
Patricia Graef, *CO*

Stephanie C. Reiniche, *Senior Manager of Standards*

SPECIAL NOTE

This American National Standard (ANS) is a national voluntary consensus Standard developed under the auspices of ASHRAE. *Consensus* is defined by the American National Standards Institute (ANSI), of which ASHRAE is a member and which has approved this Standard as an ANS, as "substantial agreement reached by directly and materially affected interest categories. This signifies the concurrence of more than a simple majority, but not necessarily unanimity. Consensus requires that all views and objections be considered, and that an effort be made toward their resolution." Compliance with this Standard is voluntary until and unless a legal jurisdiction makes compliance mandatory through legislation.

ASHRAE obtains consensus through participation of its national and international members, associated societies, and public review.

ASHRAE Standards are prepared by a Project Committee appointed specifically for the purpose of writing the Standard. The Project Committee Chair and Vice-Chair must be members of ASHRAE; while other committee members may or may not be ASHRAE members, all must be technically qualified in the subject area of the Standard. Every effort is made to balance the concerned interests on all Project Committees.

The Senior Manager of Standards of ASHRAE should be contacted for

- a. interpretation of the contents of this Standard,
- b. participation in the next review of the Standard,
- c. offering constructive criticism for improving the Standard, or
- d. permission to reprint portions of the Standard.

DISCLAIMER

ASHRAE uses its best efforts to promulgate Standards and Guidelines for the benefit of the public in light of available information and accepted industry practices. However, ASHRAE does not guarantee, certify, or assure the safety or performance of any products, components, or systems tested, installed, or operated in accordance with ASHRAE's Standards or Guidelines or that any tests conducted under its Standards or Guidelines will be nonhazardous or free from risk.

ASHRAE INDUSTRIAL ADVERTISING POLICY ON STANDARDS

ASHRAE Standards and Guidelines are established to assist industry and the public by offering a uniform method of testing for rating purposes, by suggesting safe practices in designing and installing equipment, by providing proper definitions of this equipment, and by providing other information that may serve to guide the industry. The creation of ASHRAE Standards and Guidelines is determined by the need for them, and conformance to them is completely voluntary.

In referring to this Standard or Guideline and in marking of equipment and in advertising, no claim shall be made, either stated or implied, that the product has been approved by ASHRAE.

CONTENTS

ANSI/ASHRAE Standard 52.2-2017, Method of Testing General Ventilation Air-Cleaning Devices for Removal Efficiency by Particle Size

SECTION	PAGE
Foreword	2
1 Purpose.....	3
2 Scope	3
3 Definitions and Acronyms	3
4 Test Apparatus.....	4
5 Apparatus Qualification Testing	9
6 Test Materials.....	16
7 Selection and Preparation of the Test Device	17
8 Test Procedures.....	18
9 Measurement of Resistance versus Airflow	19
10 Determination of Particle Size Efficiency.....	19
11 Reporting Results.....	25
12 Minimum Efficiency Reporting Value (MERV) for Air Cleaners.....	26
13 Normative References.....	26
Informative Appendix A: Commentary.....	30
Informative Appendix B: Test Procedure Suggestions and Examples	32
Informative Appendix C: How to Read a Test Report	38
Informative Appendix D: Minimum Efficiency Reporting Guidance	42
Informative Appendix E: Cross-Reference and Application Guidelines	44
Informative Appendix F: Acronyms and Conversion Formulae	46
Informative Appendix G: Informative References.....	47
Informative Appendix H: Addenda Description Information.....	48
Informative Appendix I: (Intentionally Left Blank)	49
Informative Appendix J: Optional Method of Conditioning a Filter Using Fine KCl Particles to Demonstrate Efficiency Loss That Might Be Realized in Field Applications	50
Informative Appendix K: Optional Method of Testing Two Air Filters Arranged in Series in a System to Evaluate Particle Removal, Dust Loading, and Pressure Drop Increase That Might Be Realized in Field Applications.....	55

NOTE

Approved addenda, errata, or interpretations for this standard can be downloaded free of charge from the ASHRAE website at www.ashrae.org/technology.

© 2017 ASHRAE

1791 Tullie Circle NE · Atlanta, GA 30329 · www.ashrae.org · All rights reserved.

ASHRAE is a registered trademark of the American Society of Heating, Refrigerating and Air-Conditioning Engineers, Inc.
ANSI is a registered trademark of the American National Standards Institute.

(This foreword is not part of this standard. It is merely informative and does not contain requirements necessary for conformance to the standard. It has not been processed according to the ANSI requirements for a standard and may contain material that has not been subject to public review or a consensus process. Unresolved objections on informative material are not offered the right to appeal at ASHRAE or ANSI.)

FOREWORD

ANSI/ASHRAE Standard 52.2-2017 incorporates addenda to the 2012 edition. The goal of the committee was to improve the end-user experience by standardizing reporting or improving the robustness of the test method to reduce variability. The committee's intentions were to provide the best possible information for the end user to select the best air-cleaning devices to protect people and equipment.

Historically, standards for testing air cleaners have been developed in response to the needs of the times. Protection of machinery and coils came first, then reduction of soiling. Now concerns about indoor air quality and respirable particles, protection of products during manufacturing, and protection of HVAC equipment have prompted development of this test standard based on particle size.

Standards Project Committee (SPC) 52.2 was first organized in 1987 to develop a particle size test procedure but was disbanded in 1990 after it became evident that basic research was needed. In 1991, a research contract (ASHRAE Research Project 671, Informative Appendix A, Reference A2) was awarded to review test methodology and recommend approaches for obtaining particle size efficiency data. After the research project was completed and accepted in 1993, SPC 52.2 was reactivated with members representing a broad range of interests. The standard was then formally published in 1999. Changes to the method have been made over the years to improve it and to make it more relevant. The 2017 edition continues that tradition. Appendix H includes a full list of changes by addendum:

- a. Modifications were made to the MERV table to adjust the threshold for specific MERVs and allow for the 16 graduations to be more observable in testing.*
- b. To address user concerns about reproducibility and reliability of the test method, ASHRAE commissioned Research Project RP-1088, a comprehensive round robin of multiple labs, including multiple levels of filtration performance. The changes in the 2017 edition of the standard are based on direct recommendations of the research project.*
- c. Changes were made with the intent of making the data on reports more mandatory. The goal of the committee was to improve user experience by ensuring that reports being provided by labs and manufacturers would share the same data, allowing for a simpler evaluation of products.*
- d. New Informative Appendix K uses the base methodology to test across sequenced filters. This allows users a method of testing their system in a controlled lab environment.*

Description of Standard

This standard addresses two air-cleaner performance characteristics of importance to users: the ability of the device to

remove particles from the airstream and its resistance to air-flow. Air-cleaner testing is conducted at airflow rates not less than 0.22 m³/s (472 cfm) nor greater than 1.4 m³/s (3000 cfm).

A sample of air from a general ventilation system contains particles with a broad range of sizes having varied effects, sometimes dependent on particle size. Coarse particles, for example, cause energy waste when they cover heat transfer surfaces. Fine particles cause soiling and discoloration of interior surfaces and furnishings as well as possible health effects when inhaled by occupants of the space. When air cleaners are tested and reported for efficiency in accordance with this standard, there is a basis for comparison and selection for specific tasks.

The test procedure uses laboratory-generated KCl particles dispersed into the airstream as the test aerosol. A particle counter measures and counts the particles in 12 size ranges, both upstream and downstream, for the efficiency determinations.

This standard also delineates a method of loading the air cleaner with synthetic dust to simulate field conditions. A set of particle size removal efficiency (PSE) performance curves at incremental dust loading is developed and, together with an initial clean performance curve, is the basis of a composite curve representing the minimum performance in each size range. Points on the composite curve are averaged and the averages are then used to determine the minimum efficiency reporting value (MERV) of the air cleaner.

Coarse air cleaners may be tested for particle size removal efficiency when they are clean, with results reported in the prescribed format. (An example of a coarse air cleaner is the so-called "furnace" filter, a flat panel with a cardboard frame and spun glass fiber media.) However, the standard also provides the basis for evaluation using the loading dust efficiency by weight, or "arrestance," as well as an estimate of predicted life called "dust holding capacity."

Electronic Air Cleaners

Some air cleaners, such as externally powered electrostatic precipitators (also known as electronic air cleaners), may not be compatible with the loading dust used in this test method. The dust contains very conductive carbon that may cause electrical shorting, thus reducing or eliminating the effectiveness of these devices and negatively affecting their MERVs. In actual applications, the efficiency of these devices may decline over time, and their service life is dependent on the conductivity and the amount of dust collected.

Passive Electrostatic Fibrous Media Air Filters

Some fibrous media air filters have electrostatic charges that may be either natural or imposed on the media during manufacturing. Such filters may demonstrate high efficiency when clean and a drop in efficiency during their actual use cycle. The initial conditioning step of the dust-loading procedure described in this standard may affect the efficiency of the filter but not as much as would be observed in actual service. Therefore, the minimum efficiency observed during testing may be higher than that achieved during actual use.

Not an Application Standard

Users should not misinterpret the intent of this standard. This is a test method standard, and its results are to be used to directly compare air cleaners on a standardized basis irrespective of their applications. Results are also used to give the design engineer an easy-to-use basis for specifying an air cleaner. It is entirely possible that an industry organization may use this test method as the basis for an application standard with, for example, different final resistances.

Footnotes are used throughout this standard to provide nonmandatory guidance for the user in addition to the nonmandatory guidance found in the informative appendices. Footnotes are for information only and are not part of the standard.

Acknowledgments

SSPC 52.2 wishes to acknowledge with thanks the contributions of many people outside the voting membership, including European filtration authorities who made suggestions through the committee's international member. We are also indebted to the many media/filter manufacturers and third-party companies that have supported the committee by providing access to skilled and informed volunteers.

1. PURPOSE

This standard establishes a test procedure for evaluating the performance of air-cleaning devices as a function of particle size.

2. SCOPE

2.1 This standard describes a method of laboratory testing to measure the performance of general ventilation air-cleaning devices.

2.2 The method of testing measures the performance of air-cleaning devices in removing particles of specific diameters as the devices become loaded by standardized loading dust fed at intervals to simulate accumulation of particles during service life. The standard defines procedures for generating the aerosols required for conducting the test. The standard also provides a method for counting airborne particles of 0.30 to 10 μm in diameter upstream and downstream of the air-cleaning device in order to calculate removal efficiency by particle size.

2.3 This standard also establishes performance specifications for the equipment required to conduct the tests, defines methods of calculating and reporting the results obtained from the test data, and establishes a minimum efficiency reporting system that can be applied to air-cleaning devices covered by this standard.

3. DEFINITIONS AND ACRONYMS

3.1 Definitions. Some terms are defined below for the purposes of this standard. When definitions are not provided, common usage shall apply (see Informative Appendix G, Reference 1).

aerosol particle counter (OPC): an instrument that samples, counts, and sizes aerosol particles. While several different technologies exist for aerosol particle counters (e.g., optical,

aerodynamic, electrostatic mobility), only optical aerosol particle counters based on light scattering are used in this standard. Optical aerosol particle counters are often referred to as "OPCs" and, when the particles are sized into a number of sizing channels, are also sometimes referred to as "aerosol spectrometers."

airflow rate: the actual volume of test air passing through the device per unit of time, expressed in m^3/s (ft^3/min [cfm]), to three significant figures.

arrestance (A): a measure of the ability of an air-cleaning device with efficiencies less than 20% in the size range of 3.0 to 10.0 μm to remove loading dust from test air. Measurements are made of the weight of loading dust fed and the weight of dust passing the device during each loading step. The difference between the weight of dust fed and the weight of dust passing the device is calculated as the dust captured by the device. Arrestance is then calculated as the percentage of the dust fed that was captured by the device.

average arrestance (A_{avg}): for an air-cleaning device with efficiencies less than 20% in the size range of 3.0 to 10.0 μm , the average value of the arrestances made on the device during the loading test, weighted by the amounts of dust fed to the device during each incremental dust loading step.

charge neutralizer: a device that brings the charge distribution of the aerosol to a Boltzman charge distribution. This represents the charge distribution of the ambient aerosol.

coefficient of variation (CV): standard deviation of a group of measurements divided by the mean.

correlation ratio data acceptance criteria: criteria used to determine the adequacy of the correlation data, further defined in Section 10.6.2.

correlation ratio (R): the ratio of downstream to upstream particle counts without the test service installed in the test duct. It is determined from the average of at least three samples. This ratio is used to correct for any bias between upstream and downstream sampling and counting systems, and its calculation is described in Section 10.3.

device: throughout this standard the word *device* refers to air-cleaning equipment used in general ventilation for the removal of particles—specifically, the air cleaner being tested.

disposable air filters: filters that are designed to operate through a specified performance range and then be discarded and replaced.

dust holding capacity (DHC): the total weight of the synthetic loading dust captured by the air-cleaning device over all of the incremental dust loading steps.

dust increment: the amount of dust fed during a definite part of the loading procedure.

face area: the gross area of the device exposed to airflow. This area is measured in a plane perpendicular to the axis of the test duct or the specified direction of airflow approaching the device. All internal flanges are a part of this area, but items such as mounting hardware and electrical raceways normally mounted out of the airstream are not included. Face area is measured in m^2 (ft^2) to three significant figures.

face velocity: the rate of air movement at the face of the device (airflow rate divided by face area), expressed in m/s (fpm) to three significant figures.

final filter: a filter used to collect the loading dust that has passed through a device during the test procedure.

final resistance: the resistance to airflow of the air-cleaning device at which the test is terminated and results calculated, expressed in Pa (in. of water).

general ventilation: the process of moving air into or about a space or removing it from the space. The source of ventilation air is either air from outside the space, recirculated air, or a combination of these.

initial resistance: the pressure loss of the device operating at a specified airflow rate with no dust load, expressed in Pa (in. of water).

isokinetic sampling: sampling in which the flow in the sampler inlet is moving at the same velocity and direction as the flow being sampled.

loading dust: a compounded synthetic dust used for air-cleaner loading. Specifications for this dust are given in Section 6.2.

media: for a fibrous-type air cleaner, media is that part of the device that is the actual dust-removing agent. Webs of spun fiberglass and papers are examples of air-filter media.

media velocity: the rate of air movement through the filter media (airflow rate divided by net effective filtering area). The term is not applicable to plate-type electronic air cleaners. Media velocity is measured in m/s (fpm) to three significant figures.

net effective filtering area: the total area in the device on which dust collects. For devices using fibrous media, it is the net upstream area of the media exposed to airflow, measured in the plane or general surface of the media. Net effective area excludes the area blocked by sealants, flanges, or supports. In electronic air cleaners, it is the total exposed surface of those electrodes available for dust precipitation, including the ionizing section but excluding supports, holes, and insulators. Net effective filtering area is measured in m^2 (ft^2) to three significant figures.

particle size: the polystyrene latex (PSL) light-scattering equivalent size expressed as a diameter in micrometers (μm , 10^{-6} m).

penetration: the fraction (percentage) of particles that pass through the air cleaner as described in Section 10.4.

penetration data acceptance criteria: criteria used to determine the adequacy of the penetration data, further defined in Section 10.6.4.

polydisperse: a characteristic of an aerosol for which the width of its number distribution shows a geometric standard deviation of $\delta_g > 1.5$.

rated airflow: the airflow rate in m^3/s (cfm) at which the device is tested. In this standard it is specified by the manufacturer in accordance with Section 8.1.

rated final resistance: the operating pressure loss at the airflow rate at which a device should be replaced or renewed, as recommended by the manufacturer, expressed in Pa (in. of water).

reference filters: dry-media-type filters that are carefully measured for resistance and initial efficiency immediately after a test system is qualified. These filters serve as references to ensure that the test system continues to operate as it did when it was qualified. See Section 5.16.1.

release rate: the particles shedding from a filter after a dust load in particles of a given size released per sample volume.

resistance: the loss of static pressure caused by the device operating at a stated airflow rate, expressed in Pa (in. of water) to an accuracy of $\pm 2.5\%$.

test aerosol: polydisperse solid-phase (i.e., dry) potassium chloride (KCl) particles generated from an aqueous solution, used in this standard to determine the particle size efficiency of the device under test. Generation of the test aerosol is described in Section 5.3.

test rig: the total assembly consisting of the test duct, the aerosol generator, the loading dust feeder, the particle counters and associated accessories, the instrumentation, and the monitoring equipment.

3.2 Acronyms

ASME	American Society of Mechanical Engineers
ASTM	American Society for Testing and Materials
CV	coefficient of variation
DHC	dust holding capacity
HEPA	high-efficiency particulate air
MERV	minimum efficiency reporting value
OPC	optical particle counter
PSE	particle size removal efficiency
PSL	polystyrene latex, referring to commercially available particles of various specific sizes
SAE	Society of Automotive Engineers
ULPA	ultra-low penetration air

4. TEST APPARATUS

4.1 Mandatory and Discretionary Requirements. Critical dimensions and arrangements of the test apparatus are shown in the figures of this section and in Section 5. All dimensions shown are mandatory unless otherwise indicated. Tolerances are given on each drawing, and either SI or I-P dimensions are acceptable for any element of the system. Units shown are in mm (in.) unless otherwise indicated. The design of equipment not specified, including but not limited to blowers, valves, and external piping, is discretionary, but the equipment must have adequate capacity to meet the requirements of this standard.

4.2 Test Duct

4.2.1 The test duct is defined in Figures 4-1, 4-2, and 4-3 and is primarily of square cross section, 610×610 mm (24×24 in.). The duct material must be electrically conductive and electrically grounded, have a smooth interior finish, and be sufficiently rigid to maintain its shape at the operating pressures. The inlet filter bank must contain high-efficiency particulate air (HEPA) filters. Increasing the cross section of the

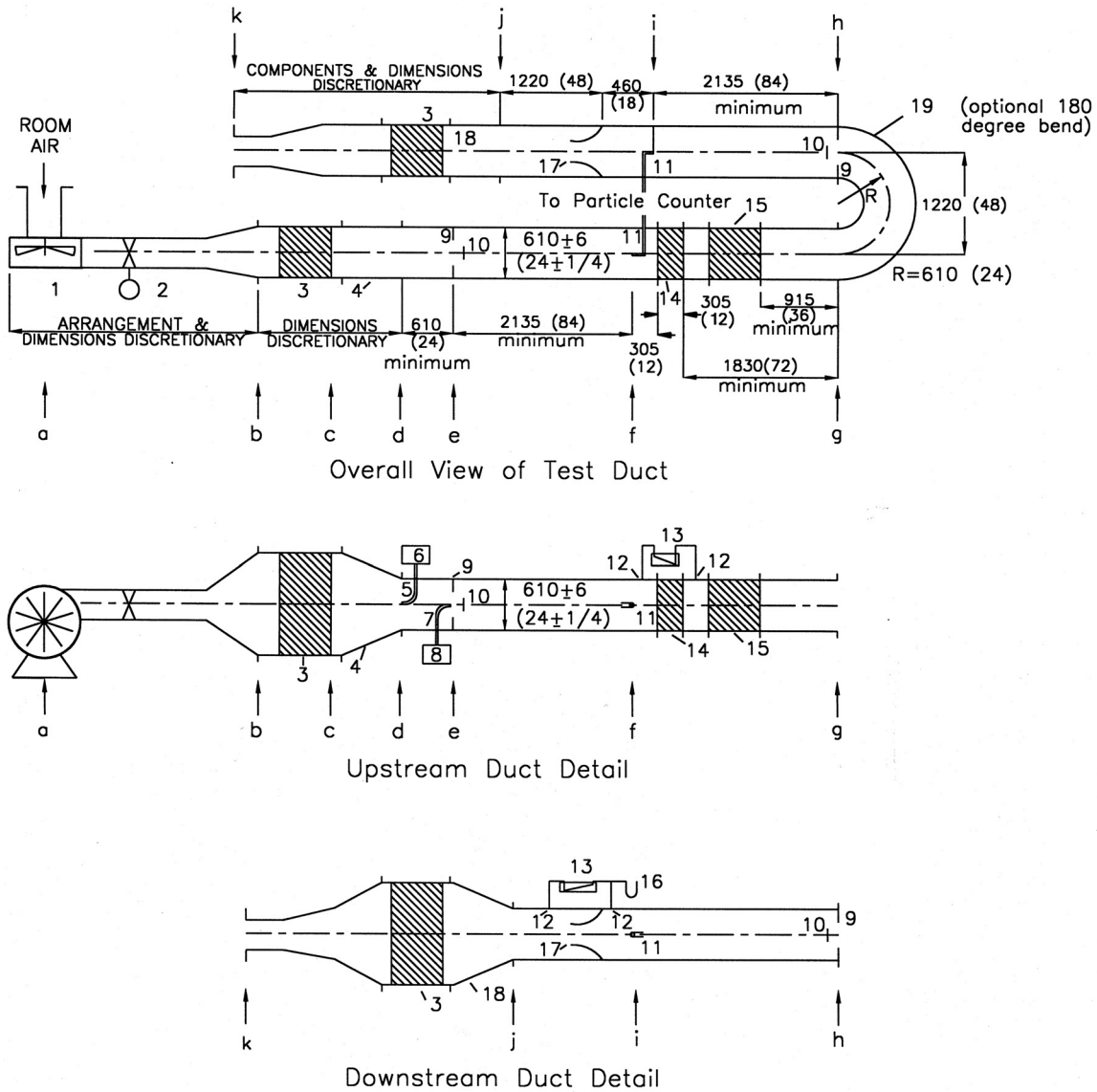

Figure 4-1 Schematic of the test duct (notes and legend are below). Dimensions are in mm (in.).

Notes for Figure 4-1:

1. Duct segments "d" through "j" shall have a cross section of 610 x 610 mm (24 x 24 in.), excluding the device section that has transitions as shown in Figures 4-3a, 4-3b, and 4-3c.
2. Segments "b" through "g" shall be in centerline alignment.
3. Segments "h" through "j" shall be in centerline alignment.
4. Upstream airflow and aerosol traverse measurements in accordance with Section 5 shall be performed at "f."
5. Aerosol injection shall occur between "c" and "e"; design discretionary in accordance with Section 4.2.4.
6. Side-by-side or over-and-under arrangements of the upstream and downstream sections of the test duct are allowed.

LEGEND FOR FIGURES 4-1 and 4-2d

- | | |
|---|---|
| 1. Blower | 10. Perforated diffusion plate |
| 2. Flow control valve | 11. Location of sample probe |
| 3. HEPA filter bank | 12. Static tap |
| 4. Transition, if any, from filter bank to 610 x 610 mm (24 x 24 in.) ducting. Maximum transition half angle = 45°. | 13. Manometer |
| 5. Aerosol injection tube | 14. Air-cleaning device and transitions (if any) |
| 6. Aerosol generator | 15. Final filter (installed only during dust loading) |
| 7. Dust feed pipe | 16. Vertical manometer |
| 8. Dust feeder | 17. Main flow measurement nozzle |
| 9. Mixing orifice | 18. Transition, if needed |
| | 19. Bend, optional |

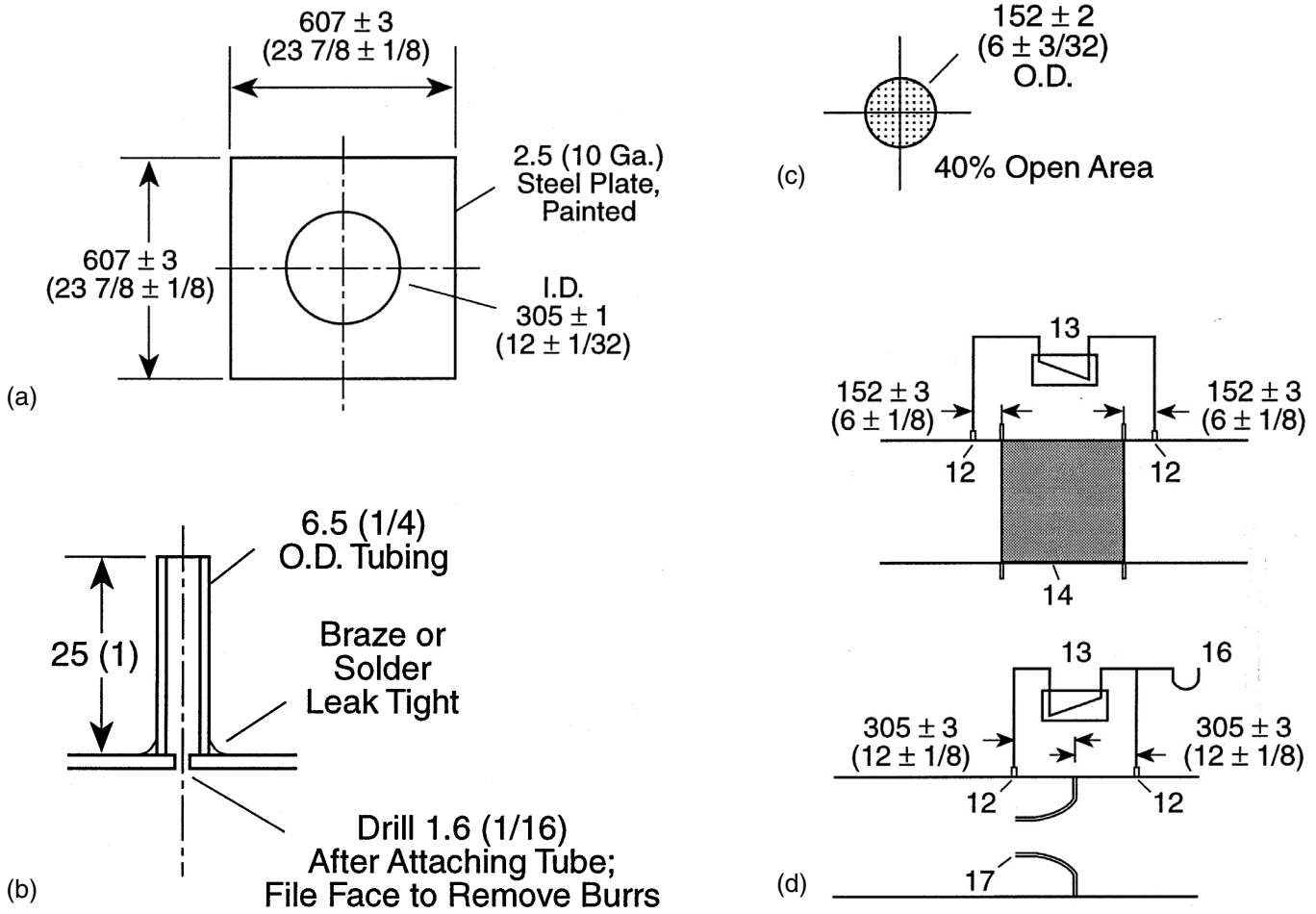

Figure 4-2 Details of test duct components. Dimensions are in mm (in.).

- (a) Mixing orifice.
- (b) Static tap.
- (c) Perforated plate with a sufficient number of equally spaced holes to provide 40% open area.
- (d) Static tap locations.

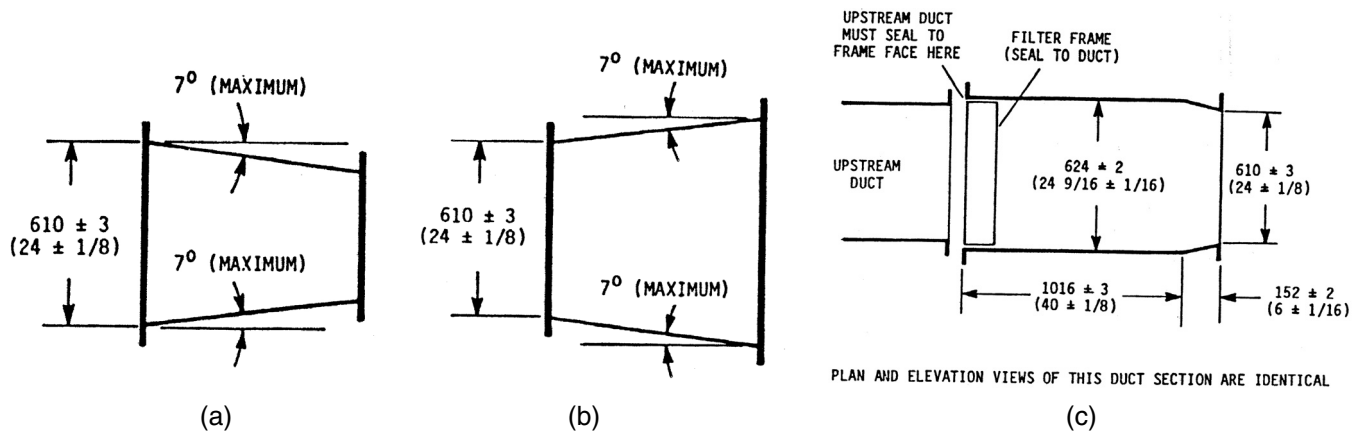

Figure 4-3 Dimensions are in mm (in.).

- (a) Transition: test air-cleaner dimensions smaller than test duct (asymmetrical dimensions are allowed).
- (b) Transition: test air-cleaner dimensions larger than test duct (asymmetrical dimensions are allowed).
- (c) Allowable special duct section for nonrigid air cleaners (must be symmetrical).

duct at the inlet filter bank to accommodate more than one 610×610 mm (24×24 in.) HEPA filter to minimize pressure drop is allowed. The inlet filter bank must discharge along the centerline of the upstream mixing orifice. System airflow is measured with an American Society of Mechanical Engineers (ASME) flow orifice (Reference 2). The duct must be operated at positive pressure, i.e., the blower discharges into the duct upstream of the test device.

4.2.2 The bend (Figure 4-1, #19) in the duct is optional, thereby allowing both a straight duct and a U-shaped duct configuration. Except for the bend itself, all dimensions and components (including the downstream mixing orifice and baffle) are the same for the straight and U-shaped configurations.

4.2.3 Room air or recirculated air shall be used as the test air source. The temperature of the air at the test device shall be between 10°C and 38°C (50°F and 100°F) with a relative humidity of $45\% \pm 10\%$ ¹. Exhaust flow shall be discharged outdoors or indoors or recirculated².

4.2.4 An orifice plate and a mixing baffle shall be located downstream of the aerosol injection point. An identical orifice plate/mixing baffle shall be located downstream of the test device³. The perforated diffusion plate should be located 152 ± 3 mm ($6 \pm 1/8$ in.) downstream of the mixing orifice and mounted so that the centerline is in line with the hole in the mixing orifice.

4.2.5 The test aerosol shall be injected into the duct between the inlet filter bank and the upstream mixing orifice. The aerosol injection system shall produce an upstream challenge that meets the qualification criteria of Section 5.3. The injection system design is discretionary so long as it fulfills this requirement.

4.2.6 The test duct shall be isolated from vibration caused by the blower or other sources of vibration.

4.2.7 The test apparatus shown in Figure 4-1 is designed for test devices with nominal face dimensions of 610×610 mm (24×24 in.). Transitions in accordance with Figures 4-3a and 4-3b shall be used for test devices with face areas from 60% to 150% of the normal test duct cross section area of 0.37 m² (4 ft²). It is permitted to test a bank of several devices if the face area of an individual device is less than 60% of the duct area. It is also permitted to test specially sized air cleaners duplicating the structure of standard units if the size requirement cannot otherwise be met.

4.3 Aerosol Generator. Other than the requirements of the following subsections, design features of the aerosol generator are discretionary. Refer to Informative Appendix B of this standard for guidance.

1. A slight temperature increase with a corresponding decrease in relative humidity will occur as the room air passes through the blower.
2. HEPA filtration of the exhaust flow is recommended when discharging indoors because test aerosol and loading dust may be present.
3. The downstream orifice serves two purposes. It straightens out the flow after going around the bend and it mixes any aerosol that penetrated the test device. Mixing the penetrating aerosol with the airstream is necessary in order to obtain a representative downstream aerosol measurement.

4.3.1 The test aerosol shall be polydisperse solid-phase (dry) potassium chloride (KCl) particles generated from an aqueous solution. The aerosol generator shall provide a stable test aerosol of sufficient concentration over the 0.30 to 10 μm diameter size range to meet the requirements of Section 10 without overloading the aerosol particle counter⁴. Refer to Section 5.6.

4.3.2 The aerosol generator shall be designed to ensure that the KCl particles are dry prior to being introduced into the test duct. The relative humidity of the airflow with the particles shall be less than 50%.

4.3.3 After drying, the aerosol shall be brought to a Boltzman electrostatic charge distribution by a beta or gamma radiation generator with an activity of at least 185 MBq (5 mCi) or a corona discharge ionizer⁵. The corona discharge ionizer shall have a minimum corona current of 3 μA and shall be balanced to provide equal amounts of positive and negative ions.

4.4 Aerosol Sampling System. Other than the requirements of the following subsections, the design features of the sampling system are discretionary. Refer to Informative Appendix B of this standard for guidance.

4.4.1 The design criterion for the sampling system shall be to provide a particle transport of $>50\%$ for 10 μm diameter KCl particles from the sample probe inlet within the test duct to the inlet of the particle counter. This shall be verified by experimental measurement or by numerical calculation of particle transport based on the geometry of the sampling system⁶, the sampling flow rate, and particle deposition associated with diffusion, sedimentation, turbulent flow, and inertial forces⁷.

4.4.2 The use of a primary and secondary sampling system is allowed to optimize particle transport from the inlet probe to the particle counter⁸. The primary/secondary sampling system shall meet the following criteria:

- a. The portion of the primary sampling line in the duct shall block less than 10% of the duct cross-sectional area.
 - b. Isokinetic sampling (to within 10%) shall be maintained on both primary and secondary probes.
4. Air-atomizing spray nozzles in which an aqueous KCl solution is nebulized with compressed air and then dried are a suitable means of aerosol generation.
 5. Electrostatic charging is an unavoidable consequence of most aerosol generation methods.
 6. For example, tube diameter, the number of bends, lengths of horizontal and vertical sections.
 7. A numerical model of aerosol transport has been developed. See Informative Appendix G, Reference 3.
 8. The primary lines (one from the upstream duct, one from the downstream duct) draw the samples from the duct and transport them to the vicinity of the particle counters. The primary system uses an auxiliary pump and flowmetering system to operate at a higher airflow rate than would be provided by the particle counters alone. The higher airflow rate combined with larger diameter sampling lines improves particle transport. The particle counters then draws a lower flow rate sample from the primary line. The sample lines from the particle counters to the primary sample lines are termed the *secondary sample lines*.

- c. Flow through the primary sampling system shall be measured to within 5% with volumetric devices (e.g., orifice plates and rotometers).
- d. Combined particle losses in the primary and secondary system shall be <50% for 10 µm diameter KCl particles, based on particle transport modeling.
- e. The upstream and downstream primary sampling systems shall be of equal length and equivalent geometry.
- f. The upstream and downstream secondary sampling systems shall be of equal length and equivalent geometry.
- g. The airflow rate of the upstream primary system shall be <2% of the system airflow rate.
- h. The airflow rate of the downstream primary system shall be <2% of the system airflow rate. The extracted airflow rate shall be added to the measured duct airflow rate to obtain the test airflow rate.
- i. The auxiliary pump and associated flow control and flow measurement devices of the primary sampling lines must be downstream of secondary probes.

4.4.3 Diluters, if used, shall provide equal dilution of both the upstream and downstream samples. Dilution of only the upstream samples is disallowed.

4.4.4 The upstream and downstream sample lines (both primary and secondary, if used) shall be made of rigid electrically grounded metallic tubing having a smooth inside surface, and they must be rigidly secured to prevent movement during testing. The upstream and downstream sample lines are to be nominally identical in geometry. The use of a short length (50 mm [2 in.] maximum) of straight, flexible, electrically dissipative tubing to make the final connection to the aerosol particle counter is acceptable⁹.

4.4.5 The inlet nozzles of upstream and downstream sample probes shall be sharp edged and of appropriate entrance diameter to maintain isokinetic sampling within 10% at the test airflow rate.

4.5 Device Flow Measurement. Flow measurement shall be made by means of ASME long-radius flow nozzles (see Figure 9-1) with static taps as in Figure 4-2b located as shown in Figure 4-2d. The temperature, absolute pressure, and relative humidity of the test airflow shall be measured in the duct immediately upstream of the flow-measuring orifice. These values shall be used for calculation of airflow rate.

4.6 Particle Counters. The particle counter specifications consist of the following:

- a. Measurement technology
- b. Size range
- c. Counting efficiency
- d. Resolution of particle size measurement
- e. Number of sizing channels and their boundaries
- f. Degree of monotonic response required
- g. Calibration methods
- h. Sampling flow rate stability
- i. Zero-count specification
- j. Requirements when dual counters are used
- k. Sample flow rate measurement and recording

9. This often relieves stress that would be placed on the instrument's inlet.

Table 4-1 Particle Counters Size Range Boundaries

Size Range	Size Range Boundaries		Geometric Mean Particle Size, µm
	Lower Limit, µm	Upper Limit, µm	
1	0.30	0.40	0.35
2	0.40	0.55	0.47
3	0.55	0.70	0.62
4	0.70	1.00	0.84
5	1.00	1.30	1.14
6	1.30	1.60	1.44
7	1.60	2.20	1.88
8	2.20	3.00	2.57
9	3.00	4.00	3.46
10	4.00	5.50	4.69
11	5.50	7.00	6.20
12	7.00	10.00	8.37

4.6.1 The aerosol particle counter shall be based on optical particle sizing and counting (i.e., light scattering). These instruments are commonly known as “optical particle counters” and also as “optical aerosol spectrometers.”

4.6.2 The particle counters shall count and size aerosol particles in the 0.30 to 10 µm diameter size range.

4.6.3 The counting efficiency shall be at least 50% for 0.3 µm NIST-traceable polystyrene latex (PSL) particles.

4.6.4 The sizing resolution of the particle counter shall be ≤10% (standard deviation/mean) and shall be measured in accordance with ISO 21501-1, ISO 21501-4, IEST-RP-CC014.1, or equivalent. The resolution shall be measured at a particle size in the range of 0.5 to 0.7 µm.

4.6.5 The particle counters shall group measured particles into 12 size ranges. The range boundaries (based on PSL calibration) shall conform to Table 4-1.

4.6.6 The particle counter's correlation of measured response¹⁰ to physical particle size shall be monotonic for PSL particles from 0.30 to 10 µm, such that only one size range shall be indicated for any measured response (i.e., any lack on monotonic response must be such that the associated ambiguity in particle size is contained within one channel of the particle counter).

4.6.7 Particle counter calibration shall conform to the following:

- a. The OPC shall be calibrated in accordance with ISO 21501-4.
- b. The calibration shall be performed with monodisperse NIST-traceable PSL.
- c. The calibration shall include at least one particle diameter in each of the ranges of 0.3 to 0.4 µm, 9 to 11 µm, and 4 other sizes in between.

10. Voltage, for example.

d. The size calibration of the particle counter shall be performed at least annually.

4.6.8 The inlet volume flow rate shall not change more than 2% with a 1000 Pa (4.0 in. of water) change in the pressure of the sampled air.

4.6.9 The total measured particle count rate shall be less than 10 particles per minute when the particle counter is sampling air with a high-efficiency filter on its intake.

4.6.10 Dual particle counters, if used, shall be identical models such that they are closely matched in design and sampling flow rate.

4.6.11 The viewed sample flow rate of the particle counter shall be recorded for each data sample.

Informative Note: Some particle counters incorporate measurement of the viewed sample flow rate within the instrument and provide that measurement as part of the data stream associated with each sample. If the particle counter does not provide this output, provisions need to be made to capture this information for each sample (such as adding a mass flowmeter on the outlet stream from the particle counter's sensor). For some particle counters, viewed sample flow rate can be significantly affected by duct pressure, which can change with flow rate; the resistance of the test filter (clean and with dust loading); and test duct setup (such as the diameter of the ASME flow nozzle and pressure drop of the outlet HEPA filter bank). Changes in flow rate through the particle counter sensor will directly change the particle count rate and lead to errors when computing the particle filtration efficiency values. Changes in flow rate may also influence the particle counter calibration.

In some cases, the influence of duct pressure can be significantly reduced by routing the exhaust of the particle counter back to the duct to equalize (or reduce) the differential pressure across the particle counter, by using a mass flow controller downstream of the particle counter's sensor, or by adding a controlled restriction in the exhaust line of the particle counter.

The viewed sample flow rate is that part of the sample stream that passes through the particle counter's sensor. In many particle counters, 100% of the sample flow flows through the sensor; in some counters and/or sampling systems, the viewed sample flow is a fraction of the total sampled flow (to allow isokinetic sampling, reduced residence time in sample line, etc.).

4.7 Test Apparatus for Dust Loading

4.7.1 The test apparatus and materials required by the dust loading procedure shall include the following:

- a. Dust feeder
- b. Dust injection tube
- c. Backup filter
- d. Backup filter duct section
- e. Loading dust
- f. Seals for the particle counter sampling probes
- g. Dust feeder venturi calibrator

4.7.2 The dust-feed tube leading from the dust feeder to the center of the dust mixing orifice shall discharge along the centerline of the mixing orifice that is located on the centerline of the test duct.

4.7.3 The general design of the dust feeder and its critical dimensions shall conform to Figures 4-4 and 4-5. Backflow through the pickup tube from the positive-pressure duct shall be prevented when the feeder is not in use¹¹.

4.7.4 The aspirator venturi dimensions shall be monitored periodically in accordance with Table 5-2 to ensure that the tolerances shown in Figure 4-5 are met¹².

4.7.5 The gage pressure on the air line to the venturi corresponding to an airflow rate out of the dust-feeder pipe of $6.8 \pm 0.2 \text{ dm}^3/\text{s}$ ($14.5 \pm 0.5 \text{ cfm}$) shall be measured periodically in accordance with Table 5-1. The required gage pressure on the ejector tube supply line necessary to provide this airflow at discharge duct pressures of 0, 500, 1000, 1500, 2000, and 2500 Pa (0, 2, 4, 6, 8, and 10 in. of water) above ambient pressure shall be determined using the test device shown in Figure 4-6. The compressed air supply shall be fitted with a filter-dryer system to provide clean, oil-free air with a dew point no higher than 1.7°C (35°F).

5. APPARATUS QUALIFICATION TESTING

5.1 Apparatus qualification tests shall verify quantitatively that the test rig and sampling procedures are capable of providing reliable particle size efficiency measurements. The tests shall be performed in accordance with Table 5-1.

Qualification tests shall be performed for the following:

- a. Air velocity uniformity in the test duct
- b. Aerosol uniformity in the test duct
- c. Downstream mixing of aerosol
- d. Overload tests of the particle counter
- e. 100% efficiency test
- f. Correlation ratio test
- g. Aerosol generator response time
- h. Duct leakage test
- i. Particle counter zero
- j. Particle counter sizing accuracy
- k. Radioactivity of the aerosol neutralizer
- l. Dust feeder airflow rate
- m. Final filter efficiency
- n. OPC documentation
- o. OPC flow-rate stability test

5.2 Velocity Uniformity in the Test Duct

5.2.1 The uniformity of the challenge air velocity across the duct cross section shall be determined by a nine-point traverse (Figure 5-1) in the $610 \times 610 \text{ mm}$ ($24 \times 24 \text{ in.}$) duct immediately upstream of the device section. The velocity

11. This can be achieved by installing a full-port ball valve in the duct feed pipe between the venturi and the test duct.
12. The thoroughness of dust dispersion by the feeder is dependent on the characteristics of the compressed air, the geometry of the aspirator assembly, and the rate of airflow through the aspirator. The aspirator venturi is subject to wear from the aspirated dust and will become enlarged with use.

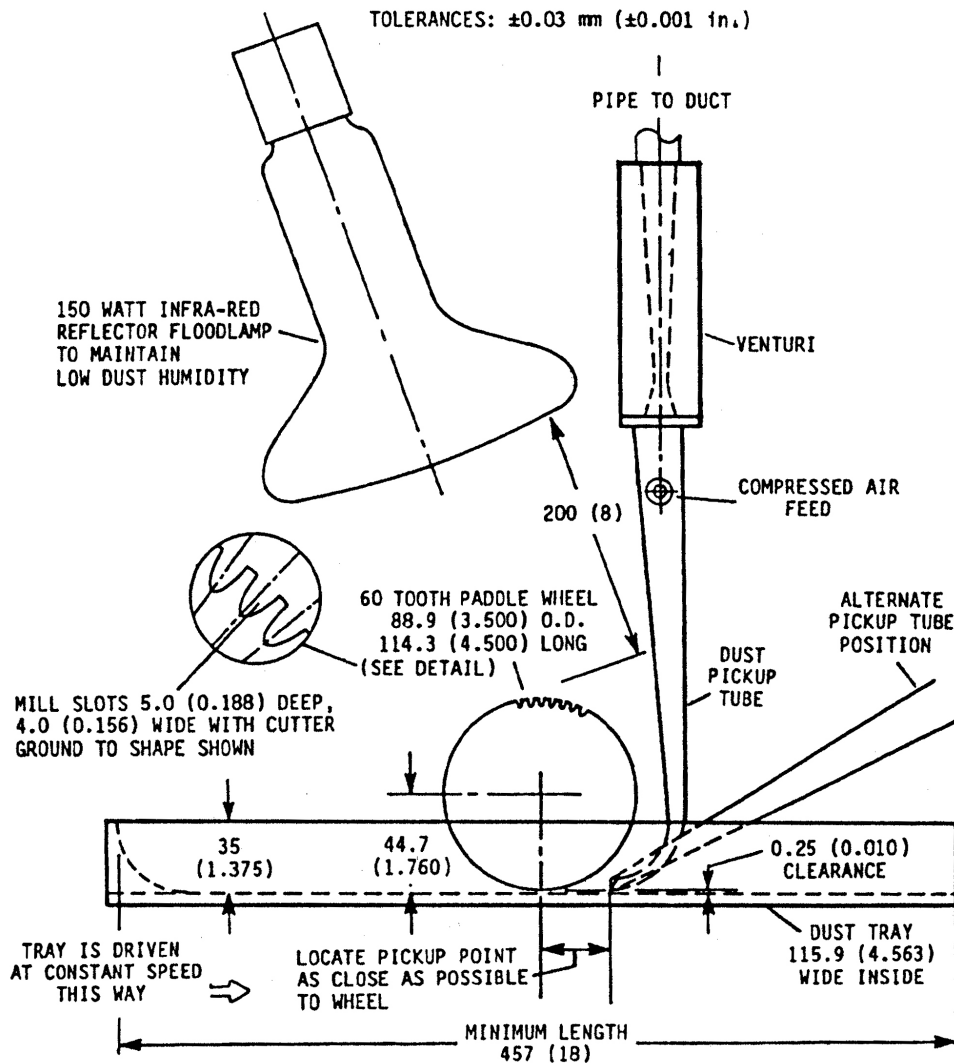

Figure 4-4 Critical dimensions of dust feeder assembly. Dimensions are in mm (in.).

measurements shall be made with an instrument having an accuracy of 10% with 0.05 m/s (approximately 10 fpm) resolution. The uniformity test shall be performed at airflow rates of 0.22, 0.93, and 1.4 m³/s (472, 1970, and 2990 cfm).

5.2.2 A one-minute average velocity shall be recorded at each grid point. The average must be based on at least ten readings taken at equal intervals during the one-minute period. The traverse shall then be repeated two more times to provide triplicate one-minute averages at each point for the given airflow rate. The average of the triplicate readings at each point shall be computed.

5.2.3 The CV (where CV is the coefficient of variation, computed as the standard deviation/mean) of the nine corresponding grid point air velocity values shall be less than 10% at each airflow rate¹³.

13. If the required degree of velocity uniformity is not achieved, confirm that the blower is providing a constant airflow rate by repeating sampling at the center-of-duct location and confirm that the upstream mixing orifice and baffle are properly centered. Changes may be required to the discretionary ductwork upstream of the upstream mixing orifice.

5.3 Aerosol Concentration Uniformity in the Test Duct

5.3.1 The uniformity of the challenge aerosol concentration across the duct cross section shall be determined by a nine-point traverse in the 610 × 610 mm (24 × 24 in.) duct immediately upstream of the device section (i.e., at the location of the upstream sample probe) using the grid points as shown in Figure 5-1. The traverse shall be made by either (a) installing nine sample probes of identical curvature, diameter, and inlet nozzle diameter but of variable vertical length or (b) repositioning a single probe. The inlet nozzle of the sample probes shall be sharp-edged and of appropriate entrance diameter to maintain isokinetic sampling within 10% at 0.93 m³/s (1970 cfm). The same inlet nozzle diameter shall be used at all airflow rates.

5.3.2 The aerosol concentration measurements shall be made with the particle counter meeting the specifications of Section 4.6. A one-minute sample shall be taken at each grid point with the aerosol generator operating. After sampling all nine points, the traverse shall be repeated four more times to provide a total of five samples from each point. The five values for each point shall then be averaged for each of the 12 particle

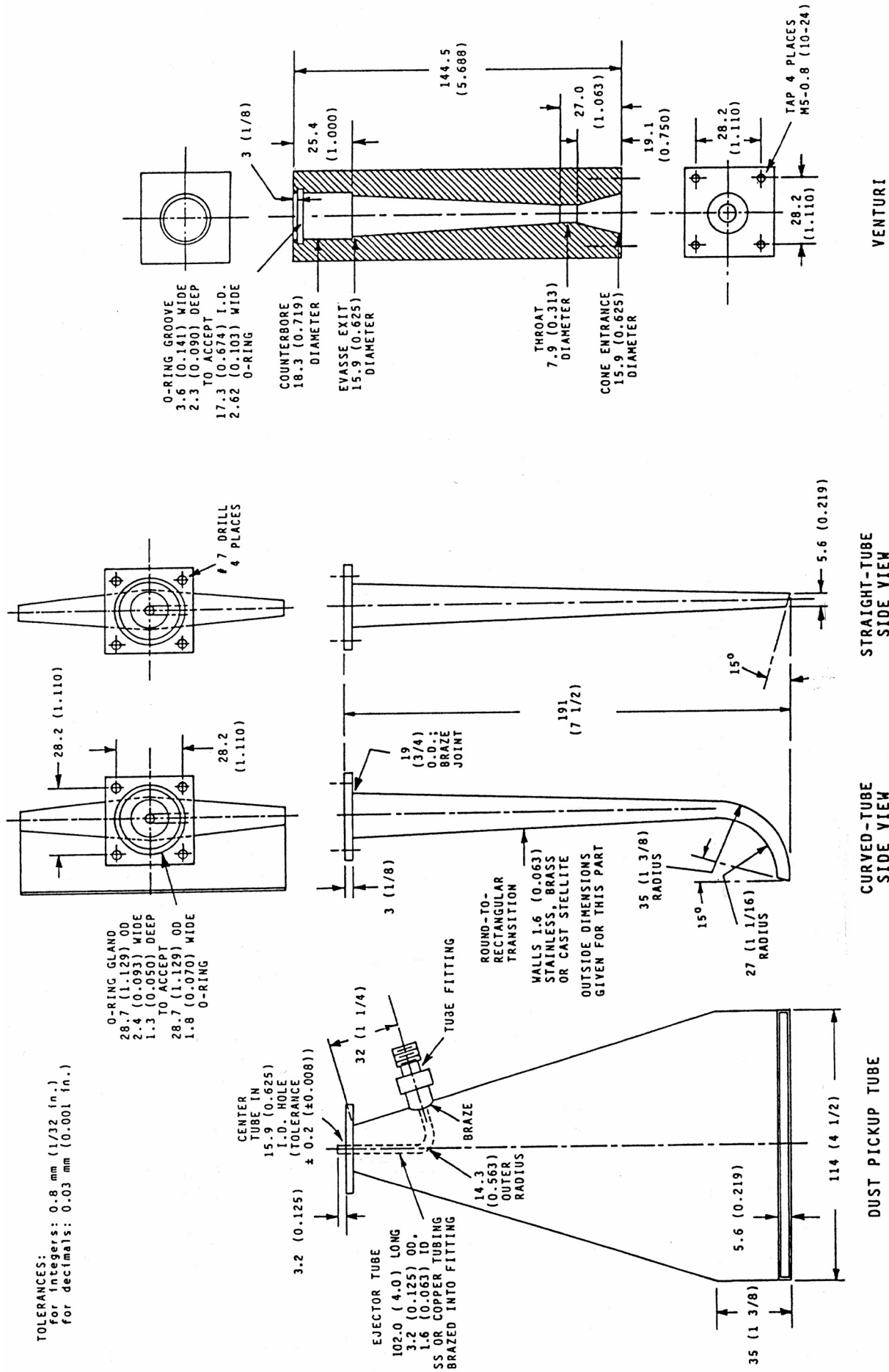

Figure 4-5 Dust feeder ejector/venturi and pickup tube details. Dimensions are in mm (in.).

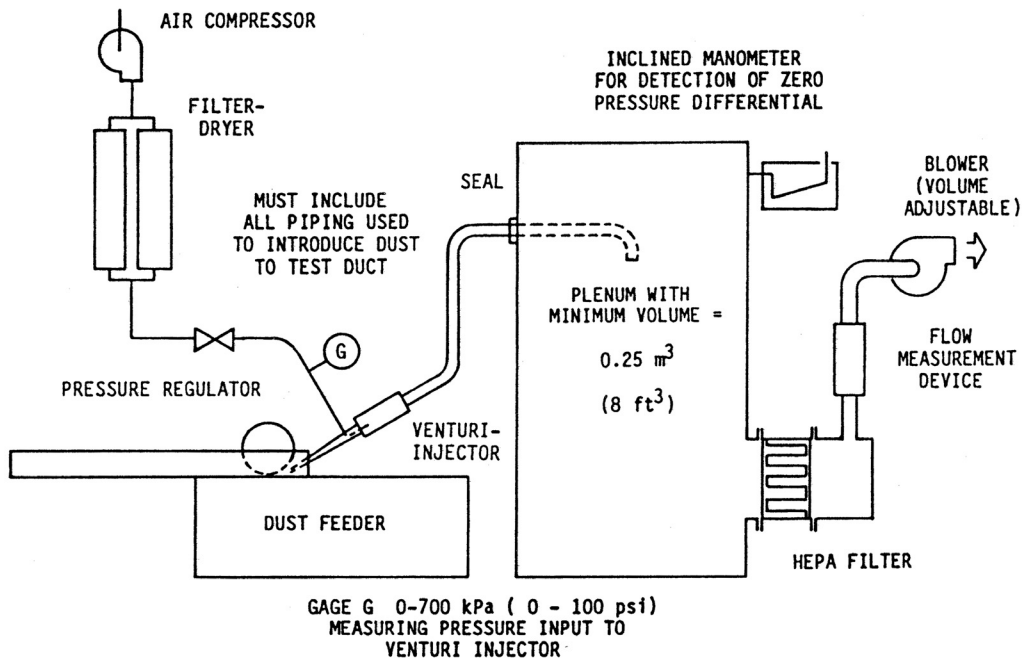

Figure 4-6 Dust feeder venturi calibrator.

Note: Gage G shall measure the pressure of the air supplied to the ejector tube supply line. This venturi calibrator shall be used to determine the pressure reading required to achieve air output from the dust feeder pipe of $6.8 \pm 0.2 \text{ dm}^3/\text{s}$ ($14.5 \pm 0.5 \text{ cfm}$) when there is zero pressure differential between the plenum and ambient. See Section 4.7.5.

Table 5-1 System Qualification Measurement Requirements

Parameter	Requirement
Air velocity uniformity: Based on traverse measurements made over a 9-point equal-area grid at each test airflow rate.	CV < 10%
Aerosol uniformity: Based on traverse measurements made over a 9-point equal-area grid at each test airflow rate.	CV < 15%
Downstream mixing: Based on a 9-point perimeter injection grid and center-of-duct downstream sampling.	CV < 10%
100% efficiency test: Based on HEPA filter test.	>99%
Correlation ratio test	0.30 to 1.0 μm : 0.90% to 1.10% 1.0 to 3.0 μm : 0.80% to 1.20% 3.0 to 10 μm : 0.70% to 1.30%
Upper concentration limit: Based on limiting the concentration to below the level corresponding to the onset of coincidence error.	No predetermined level.
Aerosol generator response time	No predetermined level.
Duct leakage: Ratio of leak rate to test airflow rate.	<1.0%
Particle counter zero count check: Based on HEPA filter attached to the instrument's inlet.	<10 counts per minute over the 0.30 to 10 μm range
Particle counter sizing accuracy check: Based on sampling of aerosolized monodisperse PSL spheres of known size.	Relative maximum must appear in the appropriate sizing channel.
Aerosol neutralizer activity: Based on detection of radioactive source within neutralizer.	Radioactivity must be detected.
Dust feeder airflow rate as a function of discharge pressure: Based on determination of gage pressure on ejector tube supply line to provide $6.8 \pm 0.2 \text{ dm}^3/\text{s}$ ($14.5 \pm 0.5 \text{ cfm}$) for discharge pressures of 0, 500, 1000, 1500, 2000, and 2500 Pa (0, 2, 4, 6, 8, and 10 in. of water) above ambient pressure.	No predetermined gage pressures. Gage pressures are recorded in order to set the proper flow rate during the dust feeder operation.
Final filter efficiency: Based on the difference between the quantity of dust injected and the quantity captured on the final filter with no test device in place.	$100 \pm 2 \text{ g}$ captured for 100 g injected.

Table 5-2 Apparatus Maintenance Schedule

Maintenance Item (Section Reference)	Incorporated Into Each Test	Monthly	Biannually	After Change that May Alter Performance	Comment
Correlation ratio measurement (5.8)	×				
Pressure drop across empty test section (5.16.2)	×				
Background particle count (10.3)	×				
Particle counter zero check (5.10)	×				
Particle counters accuracy check (5.11)	×				
Reference filter check (5.16.1)					Every two weeks
100% efficiency measurement (5.7)		×			
Particle counters primary calibration using PSL					Note 1
Air velocity uniformity (5.2)			×	×	
Aerosol uniformity (5.3)			×	×	
Downstream mixing (5.4)			×	×	
Generator response time (5.5)			×	×	
Overloading test of particle counters (5.6)			×	×	
Duct leak test (5.9)			×	×	
Confirmation of neutralizer radioactivity (5.12)			×	×	Note 5
Dust feeder airflow rate as a function of discharge pressure (5.13)			×	×	
Measurement of venturi dimensions for compliance with Figure 4-5				×	Every 500 hours of operation
Flow rates, pressure drops, temperature, relative humidity, etc.		Note 3			Note 2
Cleaning of test duct and components					Note 4

Notes:

1. Calibration performed annually.
2. In accordance with manufacturer's recommendations but at least annually.
3. Monthly visual inspection for proper installation and operation.
4. Cleaning intervals of the test duct, aerosol generator system, aerosol sampling lines, and other test components is discretionary.
5. Wash the inside of radioactive neutralizer every 100 hours of use. Check balance of the corona discharge ionizer monthly, per manufacturer's instructions.

counter size ranges. The traverse measurements shall be performed at airflow rates of 0.22, 0.93, and 1.4 m³/s (472, 1970, and 2990 cfm).

5.3.3 The CV of the corresponding nine grid point particle concentrations shall be less than 15% for each airflow rate in each of the 12 particle counter size ranges ¹⁴.

5.4 Downstream Mixing of Aerosol

5.4.1 A mixing test shall be performed to ensure that all aerosol that penetrates the air cleaner (media or frame) is detectable by the downstream sampler ¹⁵. The mixing test

14. If the required degree of aerosol uniformity is not achieved, confirm that the aerosol generator is providing a constant aerosol challenge by repeating sampling at the center-of-duct location. The aerosol injection tube may need to be repositioned and/or additional mixing baffles added to the discretionary ductwork upstream of the upstream mixing orifice.

shall be performed at airflow rates of 0.22, 0.93, and 1.4 m³/s (472, 1970, and 2990 cfm). The point of aerosol injection immediately downstream of the device section shall be traversed and the downstream sampling probe shall remain stationary in its normal center-of-duct sampling location.

5.4.2 A HEPA filter with face dimensions of 610 × 610 mm (24 × 24 in.) shall be installed to obtain smooth airflow at the outlet of the device section ¹⁶. An aerosol nebulizer shall nebulize a KCl/water solution (prepared using a ratio of 300 g of KCl to 1000 mL water) into an aerosol of primarily submicrometer sizes ¹⁷. A rigid extension tube with a length sufficient to reach each of the injection points shall be affixed to

15. For example, when testing a high-efficiency extended surface filter, it is important to know that the downstream probe will detect a leak in a corner of one of the pockets.

16. This represents a worst-case condition for aerosol mixing.

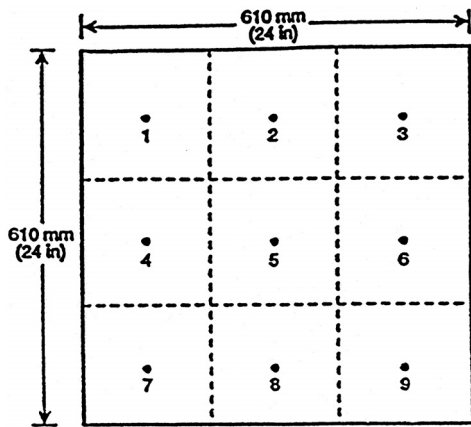

Figure 5-1 Sampling grid with nine equal-area points for measuring the uniformity of air velocity and aerosol dispersion.

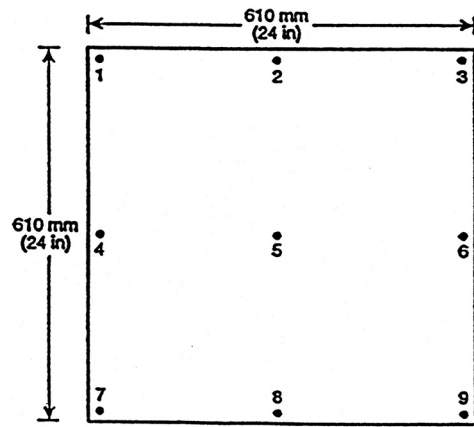

Figure 5-2 Injection grid with nine points to assess downstream mixing. Perimeter points are 25 mm (1 in.) from duct wall.

the nebulizer outlet. A 90 degree bend shall be placed at the outlet of the tube to allow injection of the aerosol in the direction of the airflow. The injection probe shall point downstream. The aerosol shall be injected immediately downstream (within 250 mm [10 in.]) of the HEPA filter at preselected points located around the perimeter of the test duct and at the center of the duct as indicated in Figure 5-2. The flow rate through the nebulizer and the diameter of the injection tube outlet shall be adjusted to provide an injection air velocity within $\pm 50\%$ of the mean duct velocity.

5.4.3 Sampling Sequence. A one-minute sample from the downstream probe shall be acquired with the nebulizer operating and the injection tube positioned at the first injection grid point. The injection point shall then be moved to the next grid-point location. A new one-minute sample shall be obtained after waiting at least 30 seconds. The procedure shall be repeated until all nine grid points have been sampled.

5.4.4 The aerosol injection traverse shall be repeated two more times to provide triplicate measurements at each grid point.

5.4.5 The downstream aerosol concentration shall be measured as total aerosol concentration $> 0.30 \mu\text{m}$ ¹⁸. The CV of the corresponding nine downstream grid-point particle concentrations shall be less than 10% for each airflow rate¹⁹.

5.5 Aerosol Generator Response Time

5.5.1 Measure the time interval for the aerosol concentration to go from background level to steady test level²⁰. The test shall be performed at an airflow rate of $0.93 \text{ m}^3/\text{s}$ (1970 cfm)

17. The nebulizer can be of any kind that produces a stable submicrometer aerosol. This nebulizer may be separate from the aerosol generator used to generate the 0.30 to $10 \mu\text{m}$ challenge aerosol for the efficiency test. A small hand-held nebulizer facilitates the traversing process.
18. The combination of (a) evaluating the downstream concentration as the total concentration $> 0.30 \mu\text{m}$ and (b) the use of a portable nebulizer greatly simplify and speed up the conduct of the test while maintaining the utility to detect inadequate downstream mixing.

with the particle counter sampling from the upstream probe. Similarly, measure the time interval for the aerosol to return to background level after turning off the generator.

5.5.2 Measure the time interval for the aerosol concentration to return to the background level after turning off the generator. These time intervals shall be used as the minimum waiting time between (a) activating the aerosol generator and beginning the particle counter sampling sequence and (b) deactivating the aerosol generator and beginning the particle counter sampling sequence for determination of background aerosol concentrations.

5.6 Concentration Limit of the Particle Counter²¹

5.6.1 A series of initial efficiency tests shall be performed over a range of challenge aerosol concentrations to determine a total concentration level for the PSE tests that does not overload the particle counters. The lowest total concentration level shall be less than 1% of the instrument's stated total concentration limit. The tests shall be performed following the procedures of Sections 10.1 through 10.6 on a media-type air cleaner using a range of upstream aerosol concentrations. The tests shall be performed at $0.93 \text{ m}^3/\text{s}$ (1970 cfm). The filters selected for this test shall have an initial efficiency in the range of 30% to 70% as measured by the 0.30 to $0.40 \mu\text{m}$ diameter size range and $> 90\%$ efficiency for the 7.0 to $10 \mu\text{m}$ diameter size range.

19. If the required degree of downstream aerosol mixing is not achieved, verify that the downstream mixing orifice and baffle are properly designed and centered. Confirm that the aerosol nebulizer is providing a stable output by injecting the aerosol at the center of the duct location while repeatedly sampling downstream. Improve the stability of the aerosol nebulizer if needed and repeat the downstream mixing test.
20. This is to ensure that sufficient time is allowed for the aerosol concentration to stabilize prior to beginning the upstream/downstream sampling sequence during the PSE tests.
21. Particle counters may underestimate particle concentrations if the concentration exceeds a certain level. Typically, errors due to overloading result in a lower air-cleaner efficiency due to underestimation of the challenge level because of coincidence error.

5.6.2 The aerosol for these tests shall be generated using the same system and procedures as specified in Section 10 for PSE tests.

5.6.3 The tests shall be performed over a sufficient range of total challenge concentrations to demonstrate that the particle counters are not overloaded at the intended test concentration ²².

5.7 100% Efficiency Test and Development of Purge Time

5.7.1 An initial efficiency test shall be performed using a HEPA or ULPA filter as the test device to ensure that the test duct and sampling system are capable of providing a >99% efficiency measurement. The test procedures for determination of PSE given in Section 10 shall be followed, and the test shall be performed at an airflow rate of 0.93 m³/s (1970 cfm).

5.7.2 The computed PSE values shall be greater than 99% for all particle sizes ²³.

5.7.3 One parameter affecting the efficiency during the 100% efficiency test is the purge time. The purge time is too short if, after switching from the upstream to the downstream line, residual particles from the upstream sample are counted during the downstream sampling and yield an efficiency of <99%. In this case, the purge time shall be increased and the 100% efficiency test repeated²⁴.

5.8 Correlation Test

5.8.1 A test shall be performed without a test device in place to check the adequacy of the overall duct, sampling, measurement, and aerosol generator.

5.8.2 The test procedures for determination of the correlation ratio given in Section 10.3 shall be followed ²⁵.

5.8.3 The correlation ratio for each particle size shall meet the requirements specified in Table 5-1 ²⁶.

5.9 Test Duct Air Leakage Test

5.9.1 Air leakage from the test duct shall not exceed 1% of the total airflow rate.

5.9.2 The leak rate of the test duct shall be evaluated by a method similar to that delineated in ANSI/ASME Standard N510 (Reference 4). The test duct shall be sealed immediately upstream of the aerosol injection location and immediately

upstream of the exhaust filter bank by bolting a gasketed solid plate to the duct opening or other appropriate means. Carefully meter air into the test duct until the lowest test pressure is achieved. The airflow rate required to maintain the pressure constant shall be measured and recorded as the leak rate, and the test shall then be repeated for the other two test pressures. The measured leak rates shall not exceed 1.0% of the corresponding test airflow rate.

5.9.3 To establish the pressure for the leak test, the pressure at the aerosol injection location shall be measured with the duct operating at airflow rates of 0.22, 0.93, and 1.4 m³/s (472, 1970, and 2990 cfm) without a test device installed. To determine the test pressures, add 250 Pa (1 in. of water) to the measured pressures to account for the added resistance of an air cleaner.

5.9.4 The highest pressure anticipated by this standard is 3200 Pa (13 in. of water). The user shall exercise caution and shall not pressurize the duct beyond its design limit for personal safety.

5.10 Particle Counters Zero. The zero count of the particle counters shall be verified to be <10 total counts per sample time used during testing in the 0.30 to 10 μm size range when operating with a HEPA filter attached directly to the instrument's inlet.

5.11 Particle Counters Sizing Accuracy. The sizing accuracy of the particle counters shall be checked by sampling an aerosol containing monodisperse polystyrene spheres of known size ²⁷. A relative maximum particle count shall appear in the particle counter sizing channel that encompasses the PSL diameter.

5.12 Confirmation of the Activity of the Aerosol Neutralizer

5.12.1 The activity of the radiation source within the aerosol neutralizer shall be confirmed by use of an appropriate radiation detection device. The measurement may be relative (as opposed to absolute) but shall be adequate to indicate the presence of an active source and shall be capable of being performed in a repeatable manner.

5.12.2 The measurement shall be repeated annually and compared to prior measurements to determine if a substantial decrease in activity has occurred. Replace neutralizers showing a lack of activity in accordance with the manufacturer's recommendations ²⁸.

5.12.3 The corona discharge level must be high enough to meet the same neutralizing level as from the radioactive source described in Section 4.3.2 ²⁹.

22. The measured filtration efficiencies should be equal over the concentration range where overloading is not significant. The measured filtration efficiency in the 0.30 to 0.40 μm diameter size range will often decrease as the concentration begins to overload the particle counter.
23. This test will assess the adequacy of the purge time interval provided between the sequential upstream-downstream concentration measurements. If the purge time is insufficient, residual particles from the relatively high concentration upstream sample will appear in the downstream sample.
24. Note that it is not necessary to define the absolute minimum purge time but rather to simply define a purge time that yields acceptable 100% efficiency tests.
25. A perfect system will yield correlation ratios of 1 at all particle sizes. Deviations from 1 can occur due to particle losses in the duct, differences in the degree of aerosol uniformity (i.e., mixing) at the upstream and downstream probes, and differences in particle transport efficiency in the upstream and downstream sample lines.

26. If the correlation ratio falls outside of the required specification at the smaller particle sizes (<1.0 μm), suspect incomplete mixing at the upstream probe location; the aerosol injection tube may need to be realigned or additional mixing provided in the discretionary ductwork upstream of the upstream orifice. If the small particles are within required limits but the larger particles are not, suspect unequal sample line losses. For dual particle-counter systems, also suspect that one of the counters may be out of calibration.
27. This is not a calibration but simply a calibration check of the particle counter.
28. For example, after one half life.

5.13 Dust Feeder Airflow Rate. Determine and record the gage pressure on the compressed air line to the venturi necessary to provide an airflow rate of $6.8 \pm 0.2 \text{ dm}^3/\text{s}$ ($14.5 \pm 0.5 \text{ cfm}$) for discharge pressures of 0, 500, 1000, 1500, 2000, and 2500 Pa (0, 2, 4, 6, 8, and 10 in. of water) above ambient pressure³⁰.

5.14 Final Filter Efficiency. Weigh the final filter to the nearest 0.1 g and install it in the test duct without the test device installed. The method specified in Section 10.7.3 shall be used to challenge the filter with 100 g of loading dust. Remove and weigh the filter. Its weight increase shall be within 2 g of 100 g.

5.15 OPC Documentation. Secure documentation from the particle counter manufacturer (or other source) that verifies that each specific particle counter requirement of Section 4.6 is being met.

5.16 OPC Flow Rate Stability Check

5.16.1 Install a flow restriction (such as an air filter or flow nozzle) in the test section of the test duct that will provide at least a 1000 Pa (4 in. of water) duct pressure difference between the upstream OPC sampling location and the downstream OPC sampling location when the duct is operated at a flow rate between 500 and 2000 cfm.

5.16.2 Operate the test duct at a flow rate that yields a 1000 Pa \pm 10% (4.0 in. of water \pm 10%) pressure differential between the upstream and downstream OPC sample locations.

5.16.3 Measure the sampled flow rate of the OPC when sampling upstream and when sampling downstream. If dual counters are used, measure the flow rate of each OPC.

5.16.4 The particle counter's viewed sample flow rate must be the instrument's specified flow rate \pm 5%.

5.16.5 The difference between the upstream and downstream viewed sample flow rates must not exceed 2%.

Informative Note to Sections 5.16.4 and 5.16.5: Corrective action, if needed, may be to route the exhaust of the particle counter back to the duct to equalize the differential pressure across the particle counter; using a mass flow controller downstream of the particle counter's sensor; or adding a controlled restriction in the exhaust line of the particle counter.

5.17 Summary of Qualification Test Requirements. Qualification test criteria shall conform to Table 5-1.

5.18 Apparatus Maintenance. Maintenance items and schedules shall conform to Table 5-2.

5.18.1 Reference Filter Check

5.18.1.1 For each test duct, a minimum of three identical reference filters shall be maintained by the testing facility solely for initial efficiency testing on a biweekly basis and shall not be exposed to dust loading. The three filters shall be labeled as "primary," "secondary," and "reserve." The primary filter shall be checked every two weeks. If the filtration effi-

ciency values shift by >5 percentage points for any of the 12 particle sizing channels, the secondary filter shall be tested³¹. If both the primary and secondary filters show shifts >5 percentage points for any of the 12 particle sizing channels, the particle counter shall be recalibrated or other system maintenance performed as needed (e.g., clean sample lines) to restore the reference filter efficiency test to a <5 percentage point shift. The reserve filter shall be used if either the primary or secondary filter becomes unusable (e.g., damaged).

5.18.1.2 The measured pressure drop across the reference filter shall be within 10% of the reference value. If the pressure drop deviates by more than 10%, system maintenance shall be performed to restore the pressure drop to within 10% of the reference value³².

5.18.1.3 The reference filter tests shall be performed at $0.93 \text{ m}^3/\text{s}$ (1970 cfm).

5.18.1.4 The filtration efficiency of the reference filters shall pass through 50% efficiency in the particle diameter range of 0.7 to 3.0 μm and be $<30\%$ efficiency at 0.30 to 0.40 μm and $>70\%$ efficiency in the 7.0 to 10.0 μm range³³.

5.18.1.5 Immediately after recalibration of the particle counters, retest each of the reference filters (or a new set of reference filters) to establish new filtration efficiency and pressure drop reference values.

5.18.1.6 When either the primary or secondary filter shows shifts >5 percentage points for any of the 12 particle size ranges and the secondary or reserve filter does not, the primary and/or secondary filter shall be replaced with an identical filter or filters, if available, or a new set of identical reference filters shall be obtained³⁴.

5.18.2 Pressure Drop Across Empty Test Section. The pressure drop across the empty test section shall be measured as part of each correlation test performed in accordance with Table 5-2. The measured pressure drop across the empty test section shall be less than 8 Pa (0.03 in. of water); system maintenance shall be performed until the pressure drop is below 8 Pa (0.03 in. of water).

6. TEST MATERIALS

6.1 Test Aerosol. The test aerosol shall be solid-phase potassium chloride (KCl) particles generated from an aqueous solution. The solution shall be prepared by dissolving reagent grade KCl in distilled water³⁵.

29. The neutralizing level may be checked using the reference filter test described in Section 5.16.1.

30. Gage pressures are used to set the proper flow rate during dust feeder operation.

31. *Percentage points* is not to be confused with *percent*. As an example, the difference between efficiency values of 30% and 35% is 5 percentage points, not 5%.

32. Examples of system maintenance steps that can be performed to restore the pressure drop include (but are not limited to) checking for leaks in the ducting and around the flow nozzle and checking the manometer for proper zero and level.

33. This is required because detecting shifts in the efficiency curves becomes difficult if the efficiency is either very high or very low for all particle sizes. Changes in the filtration efficiency of electret media reference filters may be due to reduced effectiveness of the neutralizer and its condition should then be checked.

34. A reference filter's efficiency may change with the collection of PSE test aerosol after repeated use.

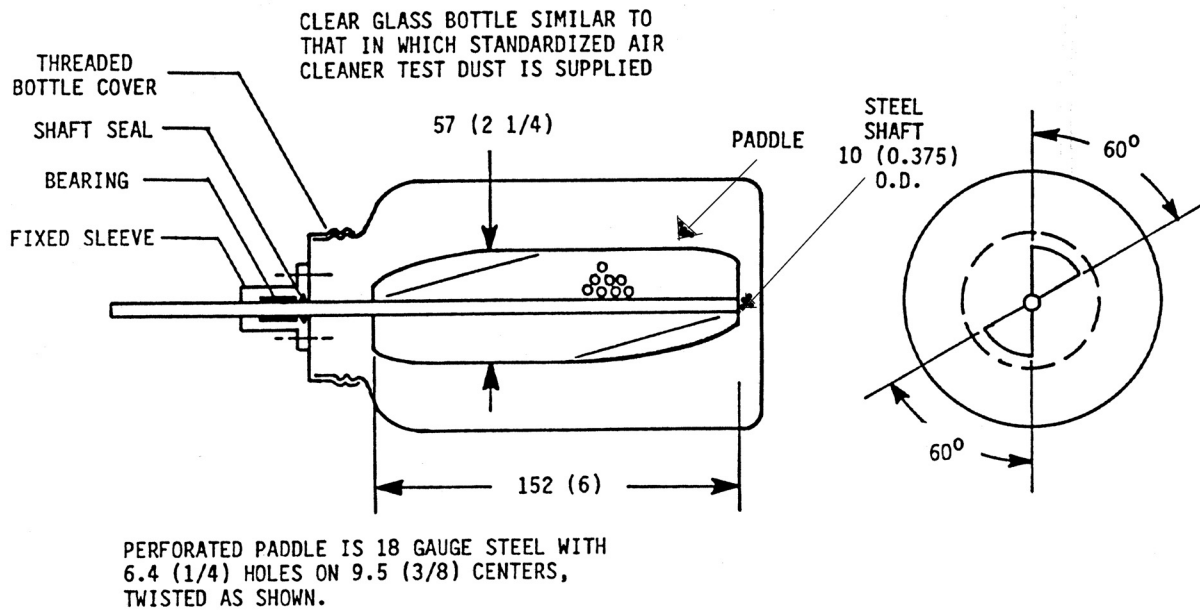

Figure 6-1 Allowable form of a loading dust blender. Dimensions are in mm (in.).

6.2 Loading Dust

6.2.1 The loading dust for testing the filtration device shall be composed, by weight, of 72% ISO 12103-1, A2 Fine Test Dust (Reference 5), 23% powdered carbon, and 5% milled cotton linters.

6.2.2 The powdered carbon shall be carbon black, with an ASTM D3765 (Reference 6) CTAB surface of $27 \pm 3 \text{ m}^2/\text{g}$, an ASTM D2414 (Reference 7) DBP adsorption of $0.68 \pm 0.7 \text{ cm}^3/\text{g}$, and an ASTM D3265 (Reference 8) tint strength of 43 ± 4 .

6.2.3 The cotton linters shall be second-cut linters removed from the cotton seed and ground in a Thomas Wiley Mill or equivalent revolving knife shearing type mill, fitted with a 4 mm screen classifier.

6.2.4 A typical 2000 g batch of test dust shall be mixed in a blender until homogeneous, as shown in Figure 6-1, or in a similar blending device as follows:

- Dry approximately 1500 g of ISO 12103-1, A2 Fine Test Dust at 104°C (220°F) for 30 minutes. Weigh $1440 \pm 1 \text{ g}$ of this dust and place in a clean blender.
- Dry approximately 600 g of the carbon powder at 104°C (220°F) for 30 minutes. Weigh $460 \pm 1 \text{ g}$ of this carbon powder and place in the blender. Mix dust and carbon powder for five minutes.
- Dry approximately 125 g of milled cotton linters in an oven at 82°C (180°F) for 30 minutes. Weigh $100 \pm 1 \text{ g}$ of these cotton linters. Sift approximately 20 g through a 14 mesh ASTM E437 (Reference 9) screen into the blender. Mix the dust-carbon powder-linter mixture for two minutes. Repeat the addition and blending of 20 g increments of linters and mixing until all 100 g of the linters and dust-powdered carbon are homogeneously blended.

35. A proportion of 300 g KCl to 1 L water is satisfactory.

6.3 Final Filter

6.3.1 Capture any test dust that passes through the test device during the dust-loading procedure in a final filter that shall be one of three different forms. In the first form, the filter shall be a flat sheet of filter media, clamped between sealing flanges and backed by a wire screen (see Figure 6-2). In the second form, the filter media shall be inserted in a holding frame in pleats that permit the use of more media than the duct cross section (see Figure 6-3). In the third form, a disposable cartridge filter shall be used (see Figure 6-4).

6.3.2 The final filter shall be capable of retaining 98% of the test dust used to load the test device. The design of the final filter and filter media shall be qualified by tests as specified in Section 5.14.

7. SELECTION AND PREPARATION OF THE TEST DEVICE

7.1 Selection Procedures

7.1.1 Devices for tests whose results reference this standard shall be selected in accordance with either Section 7.1.3 or Section 7.1.4.

7.1.2 These selection procedures shall not apply to developmental testing and the like when results are for in-house use only and not for external presentations.

7.1.3 The test sample shall be selected from a group of six or more like air cleaners taken from the manufacturer's assembly line or warehouse.

7.1.4 The test sample shall be procured on the open market by the testing laboratory.

7.2 Preparation of the Test Sample

7.2.1 The device to be tested shall be prepared in accordance with the manufacturer's recommendations.

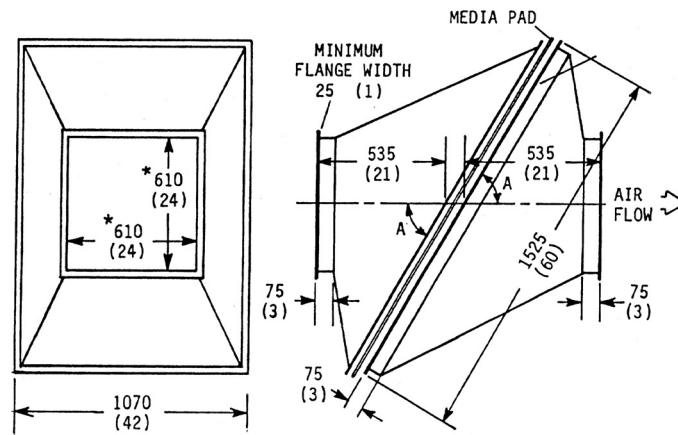

1. MEDIA PAD AND GRID/FLANGE DIMENSIONS ARE MANDATORY MINIMA, EXCEPT FOR THOSE MARKED WITH ASTERISKS (*), WHERE THE TOLERANCES ARE ± 3 ($\pm 1/8$).
2. LONGER AND WIDER PAD LENGTHS ARE PERMISSIBLE. MAXIMUM BACKUP GRID WIRE SPACING IS 51 MM (2 IN.).
3. PAD ORIENTATION MAY BE CHANGED; ANGLE "A" MAY RANGE FROM 9° TO 90°.

Figure 6-2 Final filter: flat sheet media form. Dimensions are in mm (in.).

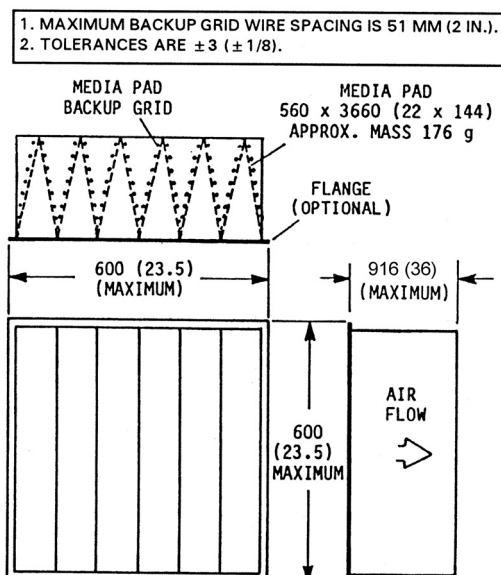

Figure 6-3 Final filter: pleated, replaceable media form. Dimensions are in mm (in.).

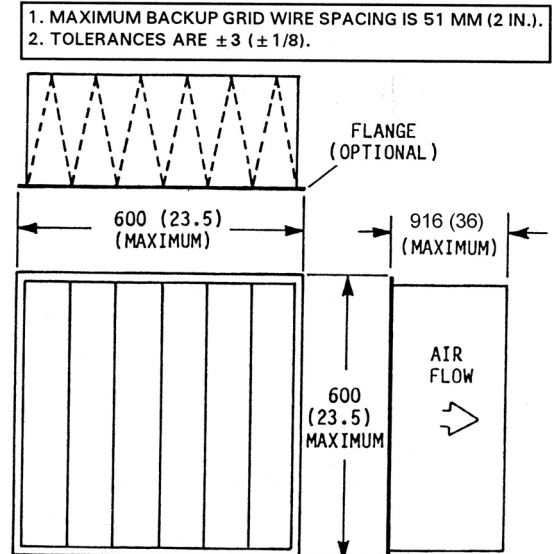

Figure 6-4 Final filter: cartridge form. Dimensions are in mm (in.).

7.2.2 The device shall be installed in the test duct so that the centerline of the airflow through the device coincides with the centerline of airflow through the duct.

7.2.3 Edge leakage and dust accumulation between the device and the test duct shall be minimized by sealing the device and its normal mounting frame to the test section on the upstream side.

8. TEST PROCEDURES

8.1 Airflow Rates for Tests. Tests shall be run and reports generated for an airflow rate as specified in either Section 8.1.1 or Section 8.1.2.

8.1.1 Airflow rates for tests conducted for MERV reporting purposes shall be at the upper limit of the test air cleaner's

application range. Also, they shall be calculated by first selecting one of the following face velocities in m/s (fpm) and then multiplying by the air cleaner's face area in m² (ft²):

0.60 (118)	2.50 (492)	1.25 (246)	3.20 (630)
1.50 (295)	3.80 (748)	1.90 (374)	

8.1.2 Test at an airflow rate corresponding to 2.50 m/s (492 fpm) if an air velocity has not been specified.

8.1.3 Test to a final resistance of 350 Pa (1.4 in. of water) if a final resistance has not been specified (otherwise test to the specified final resistance) or until the arresstance drops below 85% of the peak value, whichever comes first.

8.1.4 Adjust the airflow rate to maintain the selected face velocity when testing devices with other than 610 × 610 mm

(24 × 24 in.) face dimensions (see Section 4.2.7). Adjusted airflow rate is the product of the selected face velocity and the test device's face area.

8.2 Test Sequence. The sequence of tests on the device shall be as follows:

- Resistance vs. airflow rate of the clean device at various airflow rates as prescribed in Section 9.
- PSE of the clean device as prescribed in Section 10.
- PSE of the device when incrementally loaded with synthetic dust as prescribed in Section 10.

9. MEASUREMENT OF RESISTANCE VERSUS AIRFLOW

9.1 Install the device in the test duct.

9.2 Establish and record airflow rates measured by the flow nozzle. Refer to Figure 9-1. For the purposes of this standard, airflow rate shall be defined by the following equations³⁶:

$$Q = 1.1107 \times 10^{-6} CD^2 \{ \Delta P / [\rho(1 - \beta^4)] \}^{0.5} \quad (\text{SI units})$$

$$Q = 5.9863 \times CD^2 \{ \Delta P / (\rho[1 - \beta^4]) \}^{0.5} \quad (\text{I-P units})$$

where

- Q = test airflow rate, m³/s (cfm)
- C = coefficient of discharge = $0.9975 - 6.53 \text{ Re}^{-0.5}$
- D = nozzle throat diameter, mm (in.)
- W = duct width, mm (in.)
- β = D/W
- ΔP = nozzle pressure drop, Pa (in. of water)
- ρ = humid air density at nozzle inlet, kg/m³ (lb/ft³) (Refer to Figure 9-2 or calculate the value in accordance with Section 9 [Reference 11].)
- μ = humid air dynamic viscosity; for the purposes of this standard, it is a constant: $1.817 \times 10^{-5} \text{ N}\cdot\text{s}/\text{m}^2$ ($1.22 \times 10^{-5} \text{ lb}_m/\text{ft}\cdot\text{s}$)
- $\text{Re} = K_R Q / \mu D = K_R \rho Q / D$, where $K_R = 5.504 \times 10^7$ (16,393)

9.3 The pressure drop across the nozzle shall be at least 100 Pa (0.4 in. of water) at the test airflow rate, and the nozzle position and static taps shall conform to Figure 4-1.

9.4 Measure and record the resistance of the device at a minimum of four airflow rates: 50%, 75%, 100%, and 125% of test airflow rate. Resistance shall be measured between the static taps.

10. DETERMINATION OF PARTICLE SIZE EFFICIENCY

This section describes the sampling sequence and data analysis procedures for sequential upstream-downstream sampling with one particle counter. For dual particle counter systems with simultaneous upstream-downstream sampling, the same procedures apply except (a) the purge times do not apply and (b) the upstream counts used in the data analysis are the observed, rather than the estimated, values. The data quality

36. These expressions are derived from ASME Standard MFC-3M-1989 (Informative Appendix G, Reference 10).

requirements for single and dual particle counter systems are identical.

10.1 Symbols and Subscripts

10.1.1 Symbols

- U = upstream counts of each size range (or channel)
- D = downstream counts of each size range (or channel)
- R = correlation ratio
- P = penetration
- T = sampling time
- δ_g = standard deviation of a sample
- n = number of sample sets
- t = t distribution variable

10.1.2 Subscripts

- i = sample number
- o = observed
- c = correlation
- b = background
- t = testing an air cleaner
- u = upstream
- d = downstream
- e = estimated
- lcl = lower confidence limit
- ucl = upper confidence limit
- n = number of sample sets
- pc = particle counter

10.2 Test Sampling

10.2.1 The sampling pattern in Figure 10-1 illustrates one iteration of a sequential upstream-downstream sampling sequence. Sample counts in each size range shall be handled the same way, and this pattern shall be followed for all PSE tests. An initial upstream sample shall be followed by an upstream to downstream purge. Development of purge times is detailed in Section 5.7. The first downstream sampling shall be followed by a downstream to upstream purge and then shall be followed by another upstream sample. The last four time periods shall be repeated for as many sample sets as are required.

10.2.2 The calculations and data quality requirements of Sections 10.3 through 10.7 are performed separately for each of the 12 particle sizing ranges.

10.3 Correlation Ratio

10.3.1 The correlation ratio (R) shall be used to correct for any bias between the upstream and downstream sampling systems. The correlation ratio shall be established from the ratio of downstream to upstream particle counts without the test device installed in the test duct and before testing an air cleaner and shall be performed at the airflow rate of the air-cleaner PSE test. The general equation for the correlation ratio as used in this standard is

$$R = \frac{\text{Downstream particle concentration}}{\text{Upstream particle concentration}}$$

with the particle generator on but without a test device in place.

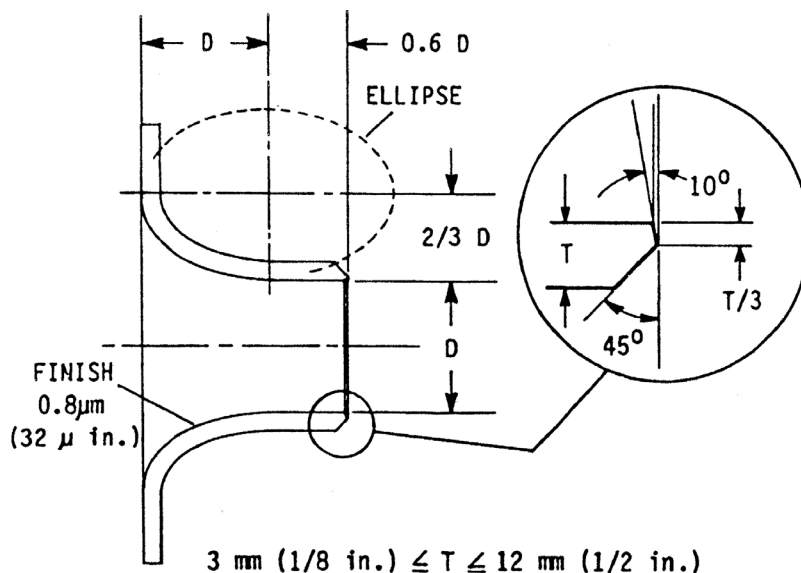

D = Nozzle throat diameter, mm (in.)

T = Nozzle wall thickness, mm (in.)

Figure 9-1 ASME long-radius flow nozzle dimensions (Reference 6).

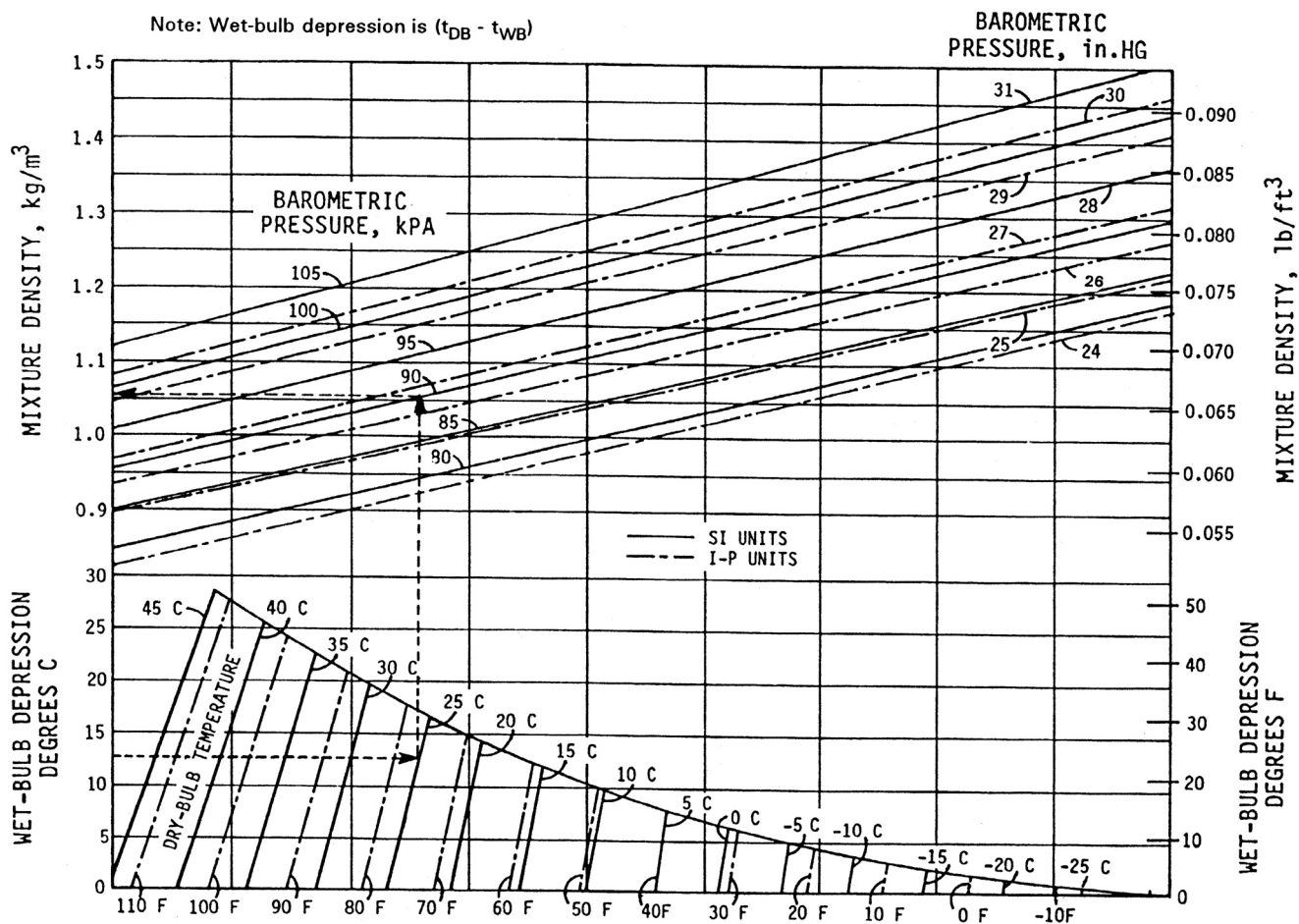

Figure 9-2 Humid air density chart. Barometric pressure as used in this chart is the absolute pressure at the nozzle inlet.

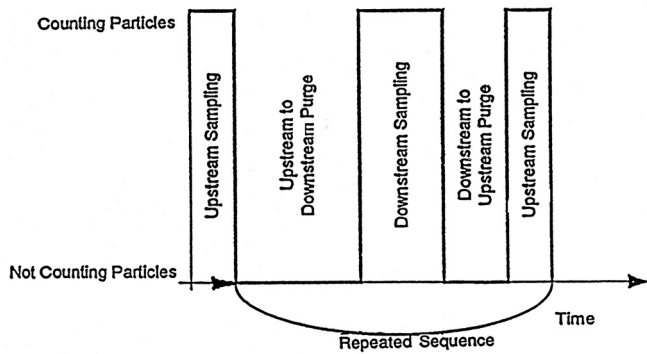

Figure 10-1 Sampling sequences.

10.3.2 Background counts shall be made before generating test aerosols. Upstream and downstream sampling shall be done sequentially, starting with an upstream sample $U_{1,o,b}$, followed by a downstream sample $D_{1,o,b}$, alternating back and forth. The total number of samples and sampling times shall be determined by the data quality requirements in Section 10.6.2, except that the final upstream sample is not needed for background sampling. Sampling times upstream and downstream shall be the same for this test.

10.3.3 Start generating aerosol when background counts are complete. Begin sampling after stabilization of the test aerosol, starting with an upstream sample $U_{1,o,c}$, followed by a downstream sample $D_{1,o,c}$. An additional upstream sample $U_{(n+1),o,c}$ shall be made following the last downstream sample $D_{n,o,c}$. The total number of samples and sampling times shall be determined by the data quality requirements in Section 10.6.2. Sampling times upstream and downstream shall be the same for this test.

10.3.4 Aerosol generation shall be turned off and background sampling shall be repeated after completion of the required correlation sampling sets.

10.3.5 The correlation ratio shall then be calculated in accordance with Section 10.6.1.

10.4 Penetration

10.4.1 The device shall be installed in the test section for determination of air-cleaner penetration. For the purposes of this standard, penetration P shall be the fraction of particles that pass through the air cleaner, and the general equation for penetration shall be

$$P = \frac{\text{Downstream particle concentration}}{\text{Upstream particle concentration}}$$

with the particle generator on and the test device in place.

10.4.2 Background counts shall be measured before generating test aerosols. Upstream and downstream sampling shall be done sequentially, starting with an upstream sample $U_{1,o,b}$, followed by a downstream sample $D_{1,o,b}$, alternating back and forth. The total number of samples and sample times shall be determined by the data quality requirements in Section 10.6.4, except that the final upstream sample is not needed for background sampling. A difference between upstream sampling time T_u and downstream sampling time T_d is allowable.

10.4.3 Start generating aerosol when background counts are complete. Start sampling with an upstream sample $U_{1,o,b}$, followed by a downstream sample $D_{1,o,b}$, after stabilization of the test aerosol. Take an additional upstream sample $U_{(n+1),o,b}$, following the last downstream sample $D_{n,o,b}$. Sampling times T_u and T_d shall be the same as those used for background sampling.

10.4.4 Aerosol generation shall be turned off and background sampling shall be repeated after completion of the required penetration sampling sets.

10.4.5 Air-cleaner penetration shall then be calculated in accordance with Section 10.6.3.

10.5 Efficiency

10.5.1 In this standard, the general equation for particle size removal efficiency³⁷ (PSE) shall be

$$\begin{aligned} \text{PSE} &= \left(1 - \frac{\text{Downstream particle concentration}}{\text{Upstream particle concentration}}\right) \times 100 \\ &= (1 - \bar{P}) \times 100 \end{aligned}$$

10.5.2 Air-cleaner efficiency shall be calculated in accordance with Section 10.6.5.

10.6 Data Reduction

10.6.1 Correlation Ratio Data Reduction

10.6.1.1 The upstream counts from two samples shall be averaged to obtain an estimate of the upstream counts that would have occurred at the same time as the downstream counts where taken³⁸.

$$U_{i,e,c} = \frac{U_{i,o,c} + U_{(i+1),o,c}}{2} \quad (10-1)$$

10.6.1.2 The background counts before and after the correlation aerosol test generation shall be simply averaged.

$$\bar{U}_b = \frac{\sum_{i=1 \rightarrow n} U_{i,o,b}}{n} \quad (10-2)$$

$$\bar{D}_b = \frac{\sum_{i=1 \rightarrow n} D_{i,o,b}}{n}$$

10.6.1.3 The correlation ratio shall be calculated for each upstream and downstream sample set using the observed downstream count, the estimated upstream count, the average downstream background count, and the average upstream background count.

$$R_i = \frac{D_{i,o,c} - \bar{D}_b}{U_{i,e,c} - \bar{U}_b} \quad (10-3)$$

37. PSE is the fraction of particles that is captured in the air cleaner.

38. For example,

$$U_{i,e,c} = \frac{U_{i,o,c} + U_{2,o,c}}{2}, U_{2,e,c} = \frac{U_{2,o,c} + U_{3,o,c}}{2}$$

10.6.1.4 These correlation ratios shall be averaged to determine a final correlation ratio value.

$$\bar{R} = \frac{\sum_{i=1 \rightarrow n} R_i}{n} \quad (10-4)$$

10.6.1.5 The standard deviation of the correlation ratio shall be determined by

$$\delta_c = \sqrt{\frac{\sum_{i=1 \rightarrow n} (R_i - \bar{R})^2}{n-1}} \quad (10-5)$$

10.6.1.6 The standard deviation of the background counts shall be determined by

$$\delta_{u,b} = \sqrt{\frac{\sum_{i=1 \rightarrow n} (U_{i,o,b} - \bar{U}_b)^2}{n-1}} \quad (10-6)$$

$$\text{and } \delta_{d,b} = \sqrt{\frac{\sum_{i=1 \rightarrow n} (D_{i,o,b} - \bar{D}_b)^2}{n-1}}$$

10.6.1.7 The 95% confidence limits of the correlation value shall be determined by

$$\bar{R}_{lcl} = \bar{R} - \delta_c \times \frac{t}{\sqrt{n}} \quad (10-7)$$

$$\text{and } \bar{R}_{ucl} = \bar{R} + \delta_c \times \frac{t}{\sqrt{n}} \quad (10-8)$$

using the t distribution variable from Table 10-1 for a given n .

10.6.1.8 The 95% upper confidence limits of the background counts shall be determined by

$$\bar{U}_{b,ucl} = \bar{U}_b + \delta_{u,b} \times \frac{t}{\sqrt{n}} \quad (10-9)$$

$$\text{and } \bar{D}_{b,ucl} = \bar{D}_b + \delta_{d,b} \times \frac{t}{\sqrt{n}} \quad (10-10)$$

using the t distribution variable from Table 10-1 for a given n .

10.6.2 Correlation Ratio Data Acceptance Criteria

10.6.2.1 Correlation Ratio Error Limit. The number of correlation sample runs n shall be at least three and sufficient to satisfy the following conditions:

$$\delta_c \times \frac{t}{\sqrt{n}} \leq 0.05 \text{ for particle size ranges 1 through 8 (10-11a)}$$

$$\delta_c \times \frac{t}{\sqrt{n}} \leq 0.10 \text{ for particle size ranges 9 and 10 (10-11b)}$$

$$\delta_c \times \frac{t}{\sqrt{n}} \leq 0.15 \text{ for particle size ranges 11 and 12 (10-11c)}$$

This requirement shall be satisfied by calculating this expression after each sample set and halting the testing sequence when the requirement is reached for each size range,

Table 10-1 t Distribution Variable (Reference 12)

Number of Samples, n	Degrees of Freedom, $\nu = n - 1$	t
3	2	4.303
4	3	3.182
5	4	2.776
6	5	2.571
7	6	2.447
8	7	2.365
9	8	2.306
10	9	2.262
11	10	2.228
12	11	2.201
13	12	2.179
14	13	2.160
15	14	2.145
16	15	2.131
17	16	2.120
18	17	2.110
19	18	2.101
20	19	2.093
21	20	2.086
22	21	2.080
23	22	2.074
24	23	2.069
25	24	2.064
26	25	2.060
27	26	2.056
28	27	2.052
29	28	2.048
30	29	2.045
infinity	infinity	1.960

or by an acceptance criterion for a predetermined number of sample sets.

10.6.2.2 Limits on Magnitude of Correlation Ratio. The correlation ratio shall meet the requirements specified in Table 5-1.

10.6.2.3 Correlation Ratio Maximum Background Counts. The 95% upper confidence limit³⁹ of the upstream

39. This requirement establishes limits on background counts and the required number of background sample sets.

and downstream background counts shall be less than 5% of the average estimated upstream count when the particle generation is on.

$$\bar{D}_{b, ucl}, \bar{U}_{b, ucl} < \frac{\sum_{i=1 \rightarrow n} U_{i, e, c}}{n \times 20} \quad (10-12)$$

10.6.2.4 Correlation Ratio Minimum Average Upstream Counts. The sum of the estimated upstream counts shall be greater than or equal to 500. If a sufficient number of counts is not obtained, the sample time or aerosol concentration shall be increased. The aerosol concentration shall not exceed the concentration limit of the particle counters, as determined by Section 5.6.

$$\sum_{i=1 \rightarrow n} U_{i, e, c} \geq 500 \quad (10-13)$$

10.6.2.5 Viewed Sample Volume. The particle counter's viewed sample flow rate must be the instrument's specified flow rate $\pm 5\%$.

10.6.3 Penetration Data Reduction

10.6.3.1 The upstream counts from the first two samples shall be averaged to obtain an estimate of the upstream counts that would have occurred at the same time as the downstream counts where taken.

$$U_{i, e, t} = \frac{U_{i, o, t} + U_{(i+1), o, t}}{2} \quad (10-14)$$

10.6.3.2 The background counts before and after the penetration test shall be simply averaged.

$$\bar{U}_b = \frac{\sum_{i=1 \rightarrow n} U_{i, o, b}}{n}$$

$$\bar{D}_b = \frac{\sum_{i=1 \rightarrow n} D_{i, o, b}}{n} \quad (10-15)$$

where n is the number of background samples taken before and after the penetration test.

10.6.3.3 The observed penetration shall be calculated for each upstream and downstream set using the observed downstream count, the upstream count, the average downstream background count, the average upstream background count, the upstream sampling time, and the downstream sampling time.

$$P_{i, o} = \frac{D_{i, o, t} - \bar{D}_b}{U_{i, e, t} - \bar{U}_b} \times \frac{T_u}{T_d} \quad (10-16)$$

10.6.3.4 These observed penetrations shall be averaged to determine an average observed penetration value.

$$\bar{P}_o = \frac{\sum_{i=1 \rightarrow n} P_{i, o}}{n} \quad (10-17)$$

10.6.3.5 The standard deviation of the observed penetration shall be determined by

$$\delta_t = \sqrt{\frac{\sum_{i=1 \rightarrow n} (P_{i, o} - \bar{P}_o)^2}{n - 1}} \quad (10-18)$$

10.6.3.6 The observed penetration shall be corrected by the correlation ratio to yield the final penetration.

$$\bar{P} = \frac{\bar{P}_o}{\bar{R}} \quad (10-19)$$

10.6.3.7 The standard deviation of the correlation ratio shall be combined with the standard deviation of the observed penetration to determine the total error by

$$\delta = \bar{P} \times \sqrt{\left(\frac{\delta_c}{\bar{R}}\right)^2 + \left(\frac{\delta_t}{\bar{P}_o}\right)^2} \quad (10-20)$$

10.6.3.8 The 95% confidence limits of the penetration shall be determined by

$$\bar{P}_{lcl} = \bar{P} - \delta \times \frac{t}{\sqrt{n}} \quad \text{and} \quad (10-21)$$

$$\bar{P}_{ucl} = \bar{P} + \delta \times \frac{t}{\sqrt{n}} \quad (10-22)$$

using the t distribution variable from Table 10-1 for a given n .

10.6.3.9 The standard deviation and 95% upper confidence limits for the background counts shall be determined using Equations 10-6, 10-9, and 10-10.

10.6.4 Penetration Data Acceptance Criteria

10.6.4.1 Penetration Error Limit. The number of sample runs n shall be at least three and sufficient to satisfy the following condition:

$$\delta \times \frac{t}{\sqrt{n}} \leq 0.07 \times \bar{P} \quad \text{or} \leq 0.05,$$

whichever is greater, for particle size ranges 1 through 8; (10-23a)

$$\delta \times \frac{t}{\sqrt{n}} \leq 0.15 \times \bar{P} \quad \text{or} \leq 0.05,$$

whichever is greater, for particle size ranges 9 and 10; (10-23b)

$$\delta \times \frac{t}{\sqrt{n}} \leq 0.20 \times \bar{P} \quad \text{or} \leq 0.05,$$

whichever is greater, for particle size ranges 11 and 12. (10-23c)

The requirement shall be satisfied by calculating this expression after each sample set and halting the testing sequence when the requirement is reached for each size range or by an acceptance criteria for a predetermined number of sample sets.

If the above condition cannot be met, the upper confidence limit for penetration (\bar{P}_{ucl}) shall be used to calculate efficiency for that size range.

10.6.4.2 Penetration Maximum Background Counts.

For correlation tests and tests before dust loading, the 95% upper confidence limits of the upstream and downstream background counts shall be less than 5% of the average estimated upstream count when the particle generation is ON.

$$\bar{D}_{b, ucl}, \bar{U}_{b, ucl} < \frac{\sum_{i=1 \rightarrow n} U_{i, e, t}}{n \times 20} \quad (10-24)$$

10.6.4.3 Penetration Minimum Upstream Counts.

The sum of the estimated upstream counts shall be greater than or equal to 500.

$$\sum_{i=1 \rightarrow n} U_{i, e, t} \geq 500 \quad (10-25)$$

10.6.5 Efficiency. Particle size removal efficiency PSE is determined by

$$PSE = (1 - \bar{P}) \times 100 \quad (10-26)$$

10.7 Test Program for Dust-Loading and Particle Size Efficiency

10.7.1 Test Procedure

10.7.1.1 The test airflow rate shall be selected in accordance with Section 8.1. The final resistance shall be chosen equal to or greater than twice the initial resistance.

10.7.1.2 Particle size efficiency measurements shall be performed at intervals during the dust-loading procedure to establish a curve of efficiency as a function of dust loading. Efficiency curves shall be drawn for any or all of the particle size ranges of the test protocol. Efficiency measurements shall be made at the following points during the dust-loading procedure:

- Before any dust is fed to the device.
- After an initial conditioning step with a dust loading of 30 g or an increase of 10 Pa (0.04 in. of water) pressure drop across the device, whichever comes first⁴⁰.
- After the dust-loading increments have achieved an airflow resistance increase of one-quarter, one-half, and three-quarters of the difference between the beginning and the prescribed end-point limit of airflow resistance.
- After the dust increment that loads the device to its prescribed end point resistance limit.

10.7.2 Dust-Loading Procedure

10.7.2.1 Weigh the final filter to the nearest 0.1 g.

10.7.2.2 The test duct shall be in the dust-loading configuration with the final filter installed. The dust feeder shall be positioned so that the feeder nozzle is centered in the inlet mixing orifice and the nozzle tip is in the same plane as the orifice. All airflow in the particle sampling lines shall be turned off and their inlets sealed to prevent the entry of loading dust.

10.7.2.3 Weigh the quantity of dust to ± 0.1 g for one increment of loading.

10.7.2.4 Distribute the dust uniformly in the dust feeder tray. Dust shall be distributed with a depth that will provide a dust concentration in the test of 70 ± 7 mg/m³ (2.0 ± 0.2 g/1000 ft³).⁴¹

10.7.2.5 Start the test duct blower and adjust to the test airflow rate for the test device.

10.7.2.6 Turn on the dust feeder heater lamp. Adjust the air pressure regulator on the dust feeder to give the required dust feeder venturi airflow rate, 0.0068 ± 0.0002 m³/s (14.5 ± 0.5 cfm). This condition shall be maintained throughout the feed period. Start the dust feeder tray drive.

10.7.2.7 Maintain the test duct airflow rate at the test flow $\pm 2\%$. After the feeder tray motion is complete, brush dust remaining in the feeder tray into the aspirator. Vibrate or rap the dust feeder tube for 30 seconds.

10.7.2.8 Turn off the feeder tray drive and the airflow to the aspirator venturi. With the test duct airflow on, reentrain any test dust in the duct upstream of the test device by use of a compressed air jet directed obliquely away from the device. Record the airflow resistance of the test device.

10.7.2.9 If several dust increments are required to achieve one quarter of the required flow resistance increase of the device, repeat the steps of Sections 10.7.2.3 through 10.7.2.8. A complete dust increment shall be fed before running the next PSE test.

10.7.2.10 Stop the test duct airflow and remove the final filter from the test duct, taking care to avoid spilling dust from the final filter. Weigh the final filter to the nearest 0.1 g.

10.7.2.11 Collect any test dust deposited in the test duct between the test filter device and the final filter. Weigh the collected dust to the nearest 0.1 g.

10.7.2.12 Add the weight of dust collected in the procedure of Section 10.7.11 to the weight increase of the final filter to establish the amount of synthetic dust passing the device during the feed period.

10.7.2.13 For air-cleaning devices with efficiencies less than 20% in the size range of 3.0 to 10.0 μ m, calculate the arrestance A_i for dust loading increment i as follows:

$$A_i = 100(1 - W_d/W_u) \quad (10-27)$$

where

A_i = arrestance for dust loading increment i

W_d = weight of synthetic loading dust passing the device

W_u = weight of dust fed

10.7.2.14 For all devices, calculate dust holding capacity (DHC) for dust loading increment i as follows:

$$DHC_i = W_u - W_d \quad (10-28)$$

where

DHC_i = dust holding capacity for dust loading increment i

41. In cases of small dust increments or high airflows, the full length of the feeder tray may not be needed.

40. See Foreword and Informative Appendix A, Section A2.2.

W_d = weight of synthetic loading dust passing the device

W_u = weight of dust fed

10.7.3 Release Rate

10.7.3.1 Airflow shall be maintained through the device for 20 minutes. Immediately after this 20 minute period, with the airflow on and the aerosol generator OFF, use the aerosol particle counter to collect downstream particle counts over a period of ten minutes. During this time, at least three samples shall be taken. Calculate the 95% upper confidence limits of the background counts for these values using Equation 10-10.

10.7.3.2 The release rate is computed as follows:

$$\text{Release rate (\%)} = \frac{D_{b, ucl}}{\sum_{i=1-n} U_{i, o, u}} \left(\frac{T_u}{T_d} \right) 100 \quad (10-29)$$

where the release rate⁴² is expressed in #/m³, the 95% upper confidence limit is the value calculated in Section 10.7.3.1, and the V_{pc} is equal to the volumetric flow rate of the particle counter, which is multiplied by the sample time of a single count.

10.7.3.3 These values shall be reported for each dust increment and size range. If a dilutor is used in sampling, the counts must be corrected by the dilution factor to reflect the actual in-duct undiluted downstream count.

10.7.3.4 The efficiency of the air cleaner in a specific size range shall be reported as 0% if during a test run for PSE in that range the PSE is negative.

10.8 Reporting Results of Loading Tests

10.8.1 Results of loading tests shall be reported in the form of PSE curves for the test device:

- a. Clean
- b. After each incremental dust loading, a total of four curves
- c. At its final loading point

10.8.2 Develop a composite minimum efficiency curve by plotting the minimum PSE in each of the 12 size ranges shown on the plots of each of the six curves from Section 10.8.1.

10.8.3 The four data points from the Section 10.8.2 composite curve in each of the three size range groups from Table 10-2 shall be averaged and the resultant three average minimum PSEs E_1 , E_2 , and E_3 shall be reported.

10.8.4 For air-cleaning devices with efficiencies less than 20% in the size range of 3.0 to 10.0 μm , calculate the average arrestance A_{avg} as follows:

42. Optical particle counters are likely to be used to obtain this measure of release rate. Because of the optical properties of the shed dust particles (light absorbing and irregular shape), the sizing of the shed particles as measured by an optical particle counter may be significantly different from their actual physical size. When comparing release rate results, the best comparison will be when the same particle counter is used in all measurements.

Table 10-2 Size Range Groups

Average Minimum PSE Designator	Corresponding Size Range Group, μm
E_1	0.30 to 1.0
E_2	1.0 to 3.0
E_3	3.0 to 10

$$A_{avg} = [1/W] \sum_{i=1}^f [W_i A_i] (\text{percent}) \quad (10-30)$$

where

W = total weight of dust fed, g

W_i = weight of dust fed during loading increment i , g

A_i = arrestance measured during loading increment i , %

f = final loading increment

10.8.5 For all devices, calculate DHC as

$$\text{DHC} = \sum_{i=1}^f \text{DHC}_i \text{ (grams)} \quad (10-31)$$

where

DHC_i = dust holding capacity for loading increment i

f = final loading increment

10.8.6 Test results shall be reported in accordance with Section 11, and the air cleaner's MERV shall be determined in accordance with Section 12.

11. REPORTING RESULTS

11.1 Test results shall be reported using the test report format shown in this standard. Figures 11-1a through 11-1e comprise the complete test report and are examples of acceptable forms. Exact formats are not required, but the report shall include the items shown.

11.2 The summary section of the performance report shall include the following information:

- a. Name and location of the test laboratory
- b. Date of the test
- c. Test operator's names
- d. Brand and model number of the particle counting and sizing devices
- e. Air-cleaner manufacturer's name (or name of the marketing organization, if different from the manufacturer)
- f. How the sample was obtained
- g. Description of the test air cleaner, including the following:
 1. Brand and model number
 2. Physical description of construction (e.g., extended surface—number of pockets or number of pleats; pleated panel—number and depth of pleats)
 3. Face dimensions and depth
 4. For fiber media air cleaners:
 - i. Type and color of media
 - ii. Effective media area
 - iii. Type and amount of dust adhesive, if known
 - iv. Electrostatic charge, if known
 5. Any other pertinent descriptive attributes

- h. Operating data as stated by the manufacturer
 1. Test conditions for reporting purposes: airflow rate and final resistance
 2. Initial and final resistances
 3. Any other operating data furnished
- i. Test data
 1. Test air temperature and relative humidity
 2. Airflow rate
 3. Type of test aerosol
- j. Results of resistance testing
 1. Initial resistance
 2. Final resistance
- k. Performance curves
 1. A curve in Figure 11-1b format of air-cleaner resistance when clean vs. airflow rates from 50% to 125% of test flow
 2. A curve in Figure 11-1c format of PSE for the clean device and for the device at each of the five loading stages
 3. A minimum PSE composite curve in Figure 11-1c format whose data points are the lowest PSEs from the six measurements in each particle size range from the curves of test results (Item k[2] above)
 4. Resistance vs. synthetic loading dust fed (for air-cleaning devices with efficiencies less than 20% in the size range of 3.0 to 10.0 μm)
- l. Minimum efficiency reporting value (MERV)
 1. The average of the minimum PSE of the four size ranges from 0.30 to 1.0 μm (E_1)
 2. The average of the minimum PSE of the four size ranges from 1.0 to 3.0 μm (E_2)
 3. The average of the minimum PSE of the four size ranges from 3.0 to 10.0 μm (E_3)
 4. MERV for the device
- m. Release rate
 1. A data table including the information in Figure 11-1d shall be included
- n. Average ASHRAE dust arrestance (for air-cleaning devices with efficiencies less than 20% in the size range of 3.0 to 10.0 μm)
- o. Dust holding capacity (DHC)

11.3 Inclusion of test data in the summary report is required. The reported data shall consist of all data recorded during the six test runs and shall be formatted similarly to Figure 11-1e.

12. MINIMUM EFFICIENCY REPORTING VALUE (MERV) FOR AIR CLEANERS

12.1 The minimum efficiency reporting value (MERV) for an air cleaner shall be based on three composite average PSE points developed from tests at the manufacturer's specified airflow rate selected in accordance with Section 8.1. Dust loading shall follow the procedure outlined in Section 10.7,

and results of the tests shall be reported in accordance with Section 10.8.

12.2 The minimum final resistance for an air cleaner shall be the same as or greater than twice the initial resistance.

12.3 The minimum efficiency reporting value in the specified size ranges and final resistance for reporting purposes shall be in accordance with Table 12-1. Air cleaners with MERV1 to MERV4 (i.e., devices with efficiencies less than 20% in the size range of 3.0 to 10.0 μm) shall also be tested in accordance with the dust-loading procedure outlined in Section 10.7.2 of this standard before using this system for reporting.

12.4 The reporting designator shall be a combination of the air cleaner's MERV and the test airflow rate (e.g., MERV10 at 0.93 indicates that the air cleaner has a MERV10 when tested at 0.93 m^3/s [1970 cfm]).

12.5 The classification term "MERV" shall only be used in the performance report and product labeling if the entire procedure prescribed by the standard has been included.

13. NORMATIVE REFERENCES

1. See informative reference list in Informative Appendix G.
2. ASME. 1972. ASME PTC (Performance Test Code) 19.5-72 Application, Part II of Fluid Meters, Sixth Edition 1971, *Interim Supplement on Instruments and Apparatus*. New York: American Society of Mechanical Engineers.
3. See informative reference list in Informative Appendix G.
4. ASME. 1989. ANSI/ASME N510, *Testing of Nuclear Air Treatment Systems*. New York: American Society of Mechanical Engineers.
5. ISO. n/d. ISO 12103-1, *A2 Fine Test Dust for Filter Evaluation, Part A, Arizona Test Dust*. Geneva, Switzerland: International Standards Organization.
6. ASTM. 1995. ASTM Standard D3765, *Test Method for Carbon Black CTAB Surface Area*. Philadelphia, PA: American Society for Testing and Materials.
7. ASTM. 1996. ASTM Standard D2414, *Test Method for Carbon Black Dibutyl Phthalate Adsorption Number*. Philadelphia, PA: American Society for Testing and Materials.
8. ASTM. 1995. ASTM Standard D3265, *Test Method for Carbon Black Tint Strength*. Philadelphia, PA: American Society for Testing and Materials.
9. ASTM. 1992. ASTM Standard E437, *Industrial Wire Cloth and Screens (Square Opening Series)*. Philadelphia, PA: American Society for Testing and Materials.
10. See informative reference list in Informative Appendix G.
11. ASHRAE. 1985. ANSI/ASHRAE Standard 51 (AMCA Standard 210-85), *Laboratory Method for Testing Fans for Rating*. Atlanta: ASHRAE.
12. CRC. 1993. *CRC Handbook of Tables for Probability and Statistics*, W.H. Beyer, Ed. Cleveland, OH: CRC Press.

ASHRAE Std. 52.2 Air Cleaner Performance Report Summary

(This report applies to the tested device only)

Laboratory Data

Report No. _____ Test No. _____ Date _____

Test laboratory _____

Operator _____ Supervisor _____

Particle counter(s): Brand _____ Model _____

Device Manufacturer's Data

Manufacturer _____

Product name _____ Model _____

Test requested by _____

Sample obtained from _____

Catalog rating: Airflow rate _____ Initial press. drop _____

Specified test conditions: Airflow rate _____

Final pressure drop _____ Face velocity _____

Device Description

Dimensions: height _____ width _____ depth _____

Generic name _____ Media type _____

Effective media area _____ Media color _____

Amount and type of adhesive _____

Other attributes _____

Test Conditions

Airflow rate _____ Temperature _____ RH _____

Test aerosol type _____

Final pressure drop _____ Face velocity _____

Remarks _____

Resistance Test Results

Initial resistance _____ Final resistance _____

Minimum Efficiency Reporting Data

Composite average efficiencies E₁ _____ E₂ _____ E₃ _____

Air cleaner average Arrestance per Std. 52.1 _____

Minimum efficiency reporting value (MERV) for the device:

Figure 11-1a Typical air-cleaner performance report summary.

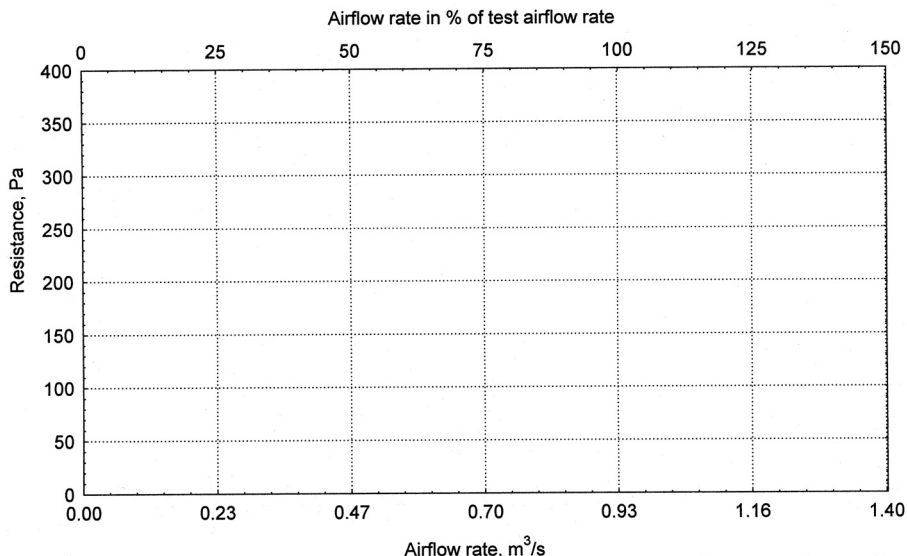

Figure 11-1b Airflow rate vs. resistance of clean device. Illustration is for an air cleaner with a test airflow rate of 0.93 m³/s (1970 cfm).

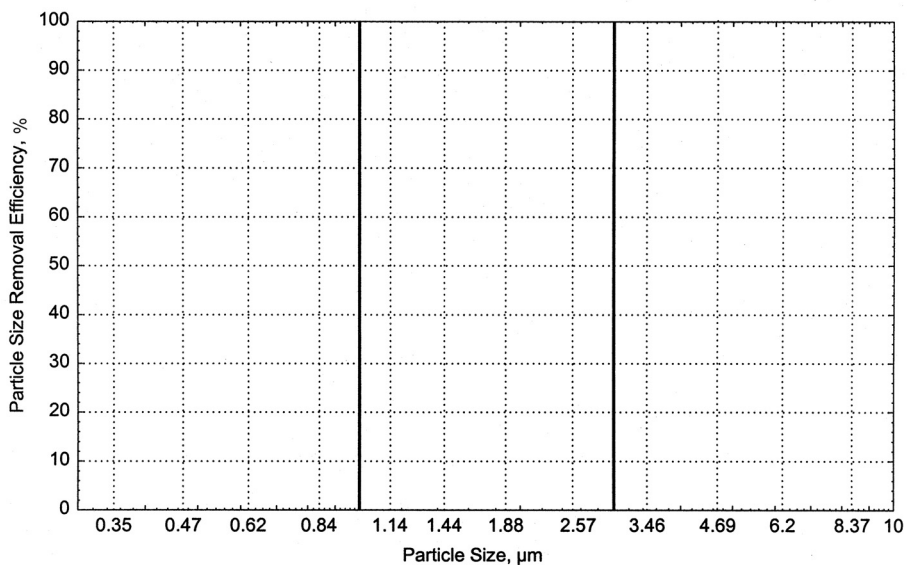

Figure 11-1c Particle size vs. efficiency.

Test Data for Release Rate						
Size Range No.	Geometric Mean of Particle Size Range, µm	Release Rate After Loading Stage 1	Release Rate After Loading Stage 2	Release Rate After Loading Stage 3	Release Rate After Loading Stage 4	Release Rate After Loading Stage 5
1	0.35					
2	0.47					
3	0.62					
4	0.84					
5	1.14					
6	1.44					
7	1.88					
8	2.57					
9	3.46					
10	4.69					
11	6.20					
12	8.37					

Figure 11-1d Release rate data report form.

Test Data for <input type="checkbox"/> Clean Device <input type="checkbox"/> Loading Stage Number _____		
Size Range No.	Geometric Mean of Particle Size Range, μm	Calculated Particle Size Efficiency, %
1	0.35	
2	0.47	
3	0.62	
4	0.84	
5	1.14	
6	1.44	
7	1.88	
8	2.57	
9	3.46	
10	4.69	
11	6.20	
12	8.37	

Figure 11-1e Test data report form.

Table 12-1 Minimum Efficiency Reporting Value (MERV) Parameters

Standard 52.2 Minimum Efficiency Reporting Value (MERV)	Composite Average Particle Size Efficiency, % in Size Range, μm			
	Range 1 0.30 to 1.0	Range 2 1.0 to 3.0	Range 3 3.0 to 10.0	Average Arrestance, %
1	N/A	N/A	$E_3 < 20$	$A_{avg} < 65$
2	N/A	N/A	$E_3 < 20$	$65 \leq A_{avg}$
3	N/A	N/A	$E_3 < 20$	$70 \leq A_{avg}$
4	N/A	N/A	$E_3 < 20$	$75 \leq A_{avg}$
5	N/A	N/A	$20 \leq E_3$	N/A
6	N/A	N/A	$35 \leq E_3$	N/A
7	N/A	N/A	$50 \leq E_3$	N/A
8	N/A	$20 \leq E_2$	$70 \leq E_3$	N/A
9	N/A	$35 \leq E_2$	$75 \leq E_3$	N/A
10	N/A	$50 \leq E_2$	$80 \leq E_3$	N/A
11	$20 \leq E_1$	$65 \leq E_2$	$85 \leq E_3$	N/A
12	$35 \leq E_1$	$80 \leq E_2$	$90 \leq E_3$	N/A
13	$50 \leq E_1$	$85 \leq E_2$	$90 \leq E_3$	N/A
14	$75 \leq E_1$	$90 \leq E_2$	$95 \leq E_3$	N/A
15	$85 \leq E_1$	$90 \leq E_2$	$95 \leq E_3$	N/A
16	$95 \leq E_1$	$95 \leq E_2$	$95 \leq E_3$	N/A

(This appendix is not part of this standard. It is merely informative and does not contain requirements necessary for conformance to the standard. It has not been processed according to the ANSI requirements for a standard and may contain material that has not been subject to public review or a consensus process. Unresolved objectors on informative material are not offered the right to appeal at ASHRAE or ANSI.)

INFORMATIVE APPENDIX A COMMENTARY

This appendix includes commentary by the project committee. Comments on some of the more important questions that were posed during the writing of this standard relate to the bend in the test duct; the use of a particle's physical size, its aerodynamic size, or its white light-scattering size; dust loading and minimum efficiency reporting; the particle size range covered by the standard; the selection of the test aerosol; and round-robin testing.

A1. BEND IN THE TEST DUCT

The test duct may be constructed with a 180 degree bend downstream of the test device. The bend serves the following purposes:

- a. It brings the downstream sample location relatively close to the upstream location, allowing short sample lines to the particle counter. Because of the physical dimensions and airflow rates involved, particle losses will generally be relatively low per unit length in the test duct and relatively high in sample lines. The bend and additional duct length provide shorter sample line length, reducing overall particle loss.
- b. It reduces the overall length of the test duct, facilitating its placement within the test room.

A2. DUST LOADING AND MINIMUM EFFICIENCY REPORTING

A2.1 Final resistance from Table 12-1 and dust loading to achieve that final resistance are simply means to identify where the air cleaner's minimum efficiency occurs. They are not intended as recommendations for use or to give any indication of actual service life. Some air cleaners have their lowest efficiency when they are clean (e.g., dry media filters); others have their highest efficiency when they are clean and drop steadily as they are loaded (e.g., electronic air cleaners). Some may drop in efficiency as they begin to be loaded (e.g., electret media) and some start low and then rise in efficiency as they are loaded but may shed dust at the end (e.g., viscous impingement filters).

A2.1.1 Electrostatic Phenomenon Considerations. The test dust and loading procedure specified herein may not be representative of real-world particulate loading and may favor or disfavor air-cleaning devices that rely on electrostatic phenomenon to enhance their performance. The electrostatic phenomenon may be natural or imposed upon the media during manufacturing. As an example of an alternative method for testing electret filters, filtration authorities in the Nordic countries have developed techniques addressing charge-removal efficiencies of fibrous electret filter materials (Reference A1).

A2.2 ASHRAE Technical Committee 2.4 funded a research project (ASHRAE RP-1190) to develop a new loading test method that would more nearly represent the minimum efficiency points in actual real-world use. The results of this research were used to develop a method of conditioning that has been demonstrated in limited cases to more closely predict filter performance in field use. This method of conditioning is now included in this standard as Informative Appendix J with an optional step to help predict the efficiency loss the filter may realize in field applications.

A3. SELECTION OF THE PARTICLE SIZE RANGE

A3.1 This section presents background information and reasons for the selection of the 0.30 to 10 μm particle size range chosen for this standard. This issue was thoroughly debated, not only during the development and monitoring of ASHRAE Research Project RP-671 (Reference A2), on which this standard is based, but also during the deliberations of the committee that formulated this document.

A3.2 The upper size limit of 10 μm was chosen to address the ability of air cleaners to remove potentially irritating and nuisance particles that adversely affect human health and air-handling equipment. Particles of this size may be trapped in the nose and cause irritation and/or allergic reactions. These particles can also soil surfaces and equipment. Such contamination can provide nutrients for biological growth in ductwork or cause duct corrosion, both of which contribute to indoor air quality (IAQ) degradation. Filtration of large particles is needed to protect air-handling systems and equipment from contamination, according to ASHRAE SSPC 62, the standing committee maintaining ANSI/ASHRAE Standard 62.1, *Ventilation for Acceptable Indoor Air Quality*.

A3.2.1 We recognize that extrapolation from 3 or 5 μm efficiencies to 10 μm is common practice. However, in ASHRAE RP-671 it was demonstrated that "bounce" of 5 to 10 μm particles in low-efficiency air-cleaner media must be taken into account, thus making extrapolation a questionable practice. A Standard 52.2 test report will show particle bounce, if any, in an air cleaner. Refer to Informative Appendix C of this standard, "How to Read a Test Report," for guidance.

A3.2.2 Recirculated air in HVAC systems may contain high concentrations of large particles. Those up to 10 μm are inhalable and affect the health-related aspects of IAQ (Reference A3). Many allergens, fungi, and bioaerosols are in the 3 to 10 μm size range (Reference A4). Large particles can also be carriers of viruses and small bioaerosols.

A3.2.3 Additional factors influenced the selection of the 10 μm size limit. Particles larger than 10 μm rarely remain airborne long enough in an indoor space to be carried to the air cleaner. Also, larger particles are difficult to generate and keep in uniform suspension during air-cleaner testing due to their high settling velocities.

A3.3 The primary reason for selecting 0.30 μm as the lower limit was to permit the test facility to choose from a wide variety of commercially available off-the-shelf particle counters. For example, white-light wide-angle-scattering optical particle counters typically have good monotonic response to polydisperse aerosols, and many have an achievable lower size limit of 0.30 μm . Expensive or custom-built particle counters are not needed for the tests.

An additional consideration is the limit of the upper-to-lower size range ratio, which is about 30 for most particle counters. Thus, if 10 μm is the upper size limit, the lower should be 0.30 μm . The ratio becomes critical if the need, cost, and the additional error source of multiple instruments are to be avoided.

A4. SELECTION OF POTASSIUM CHLORIDE AS THE TEST AEROSOL

A4.1 Particulate potassium chloride (KCl) was chosen as the test aerosol for ASHRAE Research Project RP-671 by consensus among the project monitoring committee and the research contractor. The decision was later unanimously supported by the project committee.

A4.2 Nonsynthetic outdoor (ambient) air would have been preferred as the test aerosol but it could not be used for the following reasons:

- a. It lacks a statistically significant quantity of particles $>3 \mu\text{m}$. The particle size range of this standard includes sizes up to 10 μm .
- b. It is difficult to obtain reproducible test data from laboratories located in different geographical areas, or even in the same laboratory at different times, without knowing the chemical composition of the ambient aerosol and the size distribution and concentration of the aerosol and rigid control of test hardware. The project committee chose to emphasize performance parameters and relax hardware constraints.
- c. High particle concentrations in sizes $<3 \mu\text{m}$ could overload the particle counter, and inconsistent particle size and shape could produce measurement errors.

A4.3 Potassium chloride particles have advantages over other synthetic test aerosols because they are easy to generate, have a low cost, are commonly available, and are benign to health. Potassium chloride is also a polydisperse aerosol and has a high critical relative humidity. Commentary follows on other test aerosols that were considered.

A4.3.1 Monodisperse polystyrene latex (PSL) spheres would require a repeat of the test for each particle size of interest, significantly increasing the time to develop a 0.30 to 10 μm efficiency curve. Although monodisperse PSL aerosols are routinely used for instrument calibration and in small-scale test rigs, it is difficult to generate them in sufficient concentration for the test airflows specified in this standard.

A4.3.2 Polydisperse PSL spheres or other polydisperse particles have not been standardized or defined. One type, a latex resin, may be harder to clean up because it is not water soluble.

A4.3.3 Solid-phase aerosol particles were desired for this standard because they usually present a more severe chal-

lenge to an air cleaner. They frequently bounce off collection surfaces (e.g., fibers), increasing the chance of penetration. Particle sizes $>3 \mu\text{m}$ are most likely to bounce.

A4.3.4 Sodium chloride was also considered, but it was not chosen because the relative humidity of the air must be stringently controlled at less than 55% in order to dry droplets of its solution. KCl droplets dry to solid-phase particles at a relative humidity below $\approx 70\%$.

A5. ROUND-ROBIN TESTING

A5.1 Many people, including commenters on the first public review draft of this standard, expressed a desire for round-robin testing before issuing the standard. The committee decided against it for these reasons:

- a. The method is based on ASHRAE RP-671, an advantage that ANSI/ASHRAE Standard 52-68 (and its subsequent revisions) lacked.
- b. Extensive data quality criteria are included in the standard.
- c. Very recent favorable SAE experience with a round-robin on a similar method and European experience in particle size efficiency testing in the 0.20 to 0.50 μm range indicates the validity of the method.
- d. Even if a number of laboratories could be convinced to build the expensive test rig before the standard is accepted and published, and if they were ready to start testing immediately, a round-robin would delay the standard by at least two years.

A5.2 In 2001, ASHRAE Technical Committee 2.4 funded an interlaboratory research project to quantify the repeatability and reproducibility of the 52.2-1999 procedures (ASHRAE RP-1088).

A6. APPENDIX A REFERENCES

- A1. NORDTEST. 1996. Development of test methods for electret filters. Technical Report 320, NORDTEST, Espoo, Finland.
- A2. Hanley, J.T., D.D. Smith, and D.S. Ensor. 1993. Define a fractional efficiency test method that is compatible with particulate removal air cleaners used in general ventilation. ASHRAE Research Project RP-671 Final Report, Atlanta, GA.
- A3. Suess, M. 1992. The indoor air quality program of the WHO regional office for Europe. *Proceedings of Indoor Air II*, Copenhagen, Denmark, World Health Organization.
- A4. Foarde, K.K., et al. 1994. Investigate and identify indoor allergens and biological toxins that can be removed by filtration. ASHRAE Research Project RP-760, Final Report, Atlanta, GA.

(This appendix is not part of this standard. It is merely informative and does not contain requirements necessary for conformance to the standard. It has not been processed according to the ANSI requirements for a standard and may contain material that has not been subject to public review or a consensus process. Unresolved objections on informative material are not offered the right to appeal at ASHRAE or ANSI.)

INFORMATIVE APPENDIX B TEST PROCEDURE SUGGESTIONS AND EXAMPLES

B1. INTRODUCTION

The ability to generate, sample, and measure particles over the 0.30 to 10 μm diameter size range is critical to the successful performance of a PSE test. The design of an aerosol generation system and an aerosol sampling system believed to meet the required performance criteria of this standard is described in this appendix. These designs are based on those developed in ASHRAE Research Project RP-671. This standard has intentionally made the design of the system elements discretionary so as not to hinder the development and implementation of improved methods.

B2. PARTICLE COUNTER

B2.1 The aerosol concentrations in ASHRAE RP-671 were measured with a single optical particle counter (OPC) using a white-light illumination source and a wide collection angle for

the scattered light. The OPC's sampling rate was 0.00012 m^3/s (0.25 cfm).

B2.2 The OPC output was directed to a multichannel analyzer providing the appropriate sizing channels covering the range of 0.30 to 10 μm . The multichannel analyzer was equipped with an interface board providing a contact closure at the end of each sample and a 15 second delay in particle counting after each sample. The contact closure operated electromechanical valves in the upstream and downstream sample lines. The 15 second delay allowed time for the acquisition of a new sample.

B3. AEROSOL GENERATION

B3.1 The test aerosol in ASHRAE RP-671 was solid-phase dry potassium chloride (KCl) in particulate form generated from an aqueous solution. The aerosol was generated by nebulizing an aqueous KCl solution with an external mixing air atomizing nozzle (Figure B-1). The spray nozzle was operated at a relatively low air pressure to keep the particle concentrations in the duct below the coincidence error concentration limit of the particle counter.

B3.2 The nozzle was positioned at the top of a 310 mm (12 in.) diameter, 1300 mm (51 in.) high transparent acrylic spray tower. The tall tower served two purposes: it allowed the salt droplets to dry by providing an approximately 40 second mean residence time, and it allowed larger-sized particles to fall out of the aerosol. An aerosol neutralizer reduced the charge level on the aerosol until the level was equivalent to a Boltzman charge distribution. A Boltzman charge distribution is the average charge found in the ambient air. Electrostatic charging is an

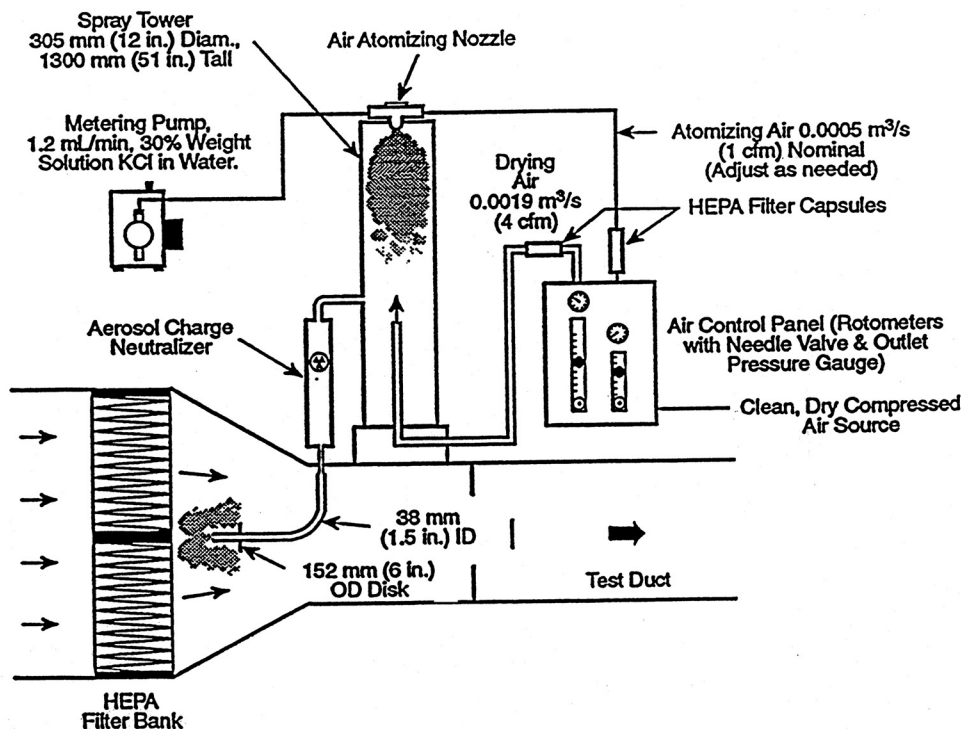

Figure B-1 Schematic of the aerosol generator system.

unavoidable consequence of most aerosol generation methods. The aerosol was injected counter to the airflow, as illustrated in Figure B-1, to improve the mixing of the aerosol with the air-stream.

B3.3 The KCl solution was prepared by combining 300 g of KCl with 1 L of distilled water. The solution was fed to the atomizing nozzle at 1.18 mL/min by a metering pump. Varying the operating air pressure of the generator allowed control of the challenge aerosol concentration.

B4. AEROSOL SAMPLING SYSTEM

B4.1 The sampling lines must be carefully designed and constructed to minimize the loss of particles. In ASHRAE RP-671, 14 mm (0.55 in.) ID stainless steel lines and gradual bends (radius of curvature = 57 mm [2.25 in.]) were used. These dimensions were chosen to minimize particle losses within the lines at the sampling rate of 0.00012 m³/s (0.25 cfm).

B4.2 The “Y” fitting connecting the upstream and downstream lines to the particle counter was custom made (Figure B-2). The two branches of the “Y” merge gradually to minimize particle loss in the intersection of the “Y” due to impaction forces.

B4.3 Electrically actuated ball valves were installed in each branch immediately above the “Y.” The opening and closing action of the valves was automatically controlled by a relay closure on the particle counter’s multichannel analyzer. The valves took approximately two seconds to open or close.

B4.4 Isokinetic sampling nozzles of the appropriate entrance diameter were placed on the ends of the sample probes to maintain isokinetic sampling for all test airflow rates.

B5. EXAMPLES OF AIR-CLEANER EFFICIENCY CALCULATIONS

B5.1 Correlation Calculations

B5.1.1 Figure B-3 shows an example correlation calculation for all particle size ranges. Here a fixed number of samples sets (nine) is used. The correlation ratios R are determined for each particle size range. The resulting correlation ratio error limits,

$$\sigma_c \times \frac{t}{\sqrt{n}}$$

are found for each particle size range and compared to the criteria in Equation 10-11 of Section 10.6.2.1. Also, the correlation ratio maximum background counts $\bar{D}_{b, ucl}, \bar{U}_{b, ucl}$ are calculated and compared to the criteria in Equation 10-12 of Section 10.6.2.3. Lastly, the correlation ratio minimum average upstream counts Avg. $U_{e,c}$ are calculated and compared to the criteria in Equation 10-13 of Section 10.6.2.4.

B5.1.2 Figure B-4 shows an example correlation calculation for a single particle size range. Here the correlation ratio error limit is calculated at the third measurement. The correlation ratio error limit is recalculated for each additional upstream and downstream measurement set. The test can be stopped when the correlation ratio error limit criterion of Section 10.6.2.1 is met.

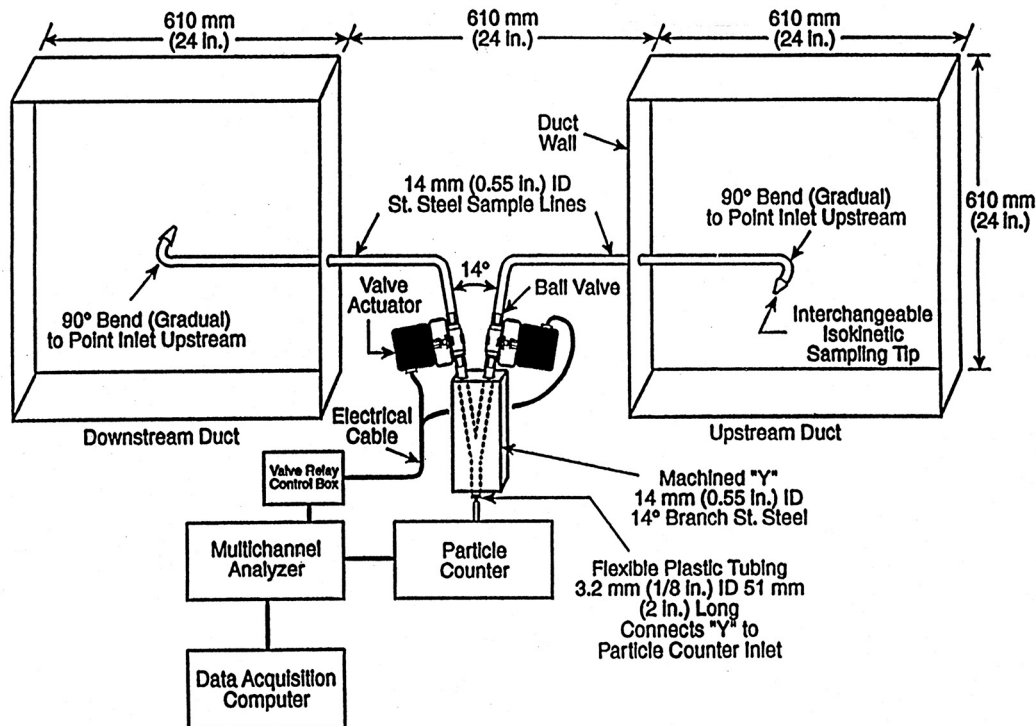

Figure B-2 Schematic of the aerosol sampling system.

OPC Channel # Geo. Mean Dia. (µm)	1 0.35	2 0.45	3 0.55	4 0.69	5 0.89	6 1.22	7 1.73	8 2.45	9 3.46	10 4.69	11 6.20	12 8.37
Upstream—Bkg	139	0	0	0	0	0	1	0	1	0	0	1
Upstream—Bkg	110	0	0	3	0	0	1	1	1	2	1	0
Upstream—Bkg	106	1	2	0	1	2	0	0	1	0	1	2
Upstream—Bkg	101	3	0	0	0	1	0	0	0	2	0	0
Upstream—Bkg	69	0	2	3	1	0	4	4	5	1	9	4
Upstream	26290	26890	20170	24870	13040	21590	26320	8967	2881	1603	697	440
Upstream	26390	27240	20410	25320	13260	21830	26310	9273	3040	1688	722	451
Upstream	26080	26560	19840	24960	13030	21640	26060	9010	2922	1697	732	446
Upstream	26240	26780	20050	25120	13140	21570	26330	9312	2927	1727	736	428
Upstream	25530	25590	19330	24360	12600	20810	25520	8724	2777	1619	659	430
Upstream	25600	26560	19780	24710	12900	21180	25460	8877	2931	1620	695	456
Upstream	24720	25410	19020	24000	12430	20680	25020	8662	2855	1551	657	412
Upstream	25550	25650	19250	24220	13070	21130	25620	8909	2857	1647	675	468
Upstream	24970	25490	19030	23780	12580	20610	25040	8468	2817	1540	612	382
Upstream	25190	25280	18960	24050	12490	20400	24770	8623	2705	1540	609	406
Upstream—Bkg	102	0	1	1	0	0	0	4	1	2	1	0
Upstream—Bkg	109	0	0	0	0	02	2	4	2	1	0	0
Upstream—Bkg	124	1	0	0	0	0	0	0	0	0	0	0
Upstream—Bkg	111	1	0	0	0	0	0	1	1	0	0	0
Upstream—Bkg	94	0	1	0	0	0	0	1	1	1	0	0
Avg. U_b	106.5	0.6	0.6	0.7	0.2	0.5	0.8	1.5	1.3	0.9	1.2	0.7
Std. Dev. U_b	18.30	0.97	0.84	1.25	0.42	0.85	1.32	1.78	1.42	0.88	2.78	1.34
$U_{b, ucl}$	119.59	1.29	1.20	1.60	0.50	1.11	1.74	2.77	2.31	1.53	3.19	1.66
Avg. U_c^*	25656	26145	19584	24539	12854	21144	25645	8882.5	2871.2	1623.2	679.4	431.9
$U_{b, ucl}/\text{Avg. } U_c^\dagger$	0.005	0.000	0.000	0.000	0.000	0.000	0.000	0.000	0.001	0.001	0.005	0.004
Downstream—Bkg	125	12	0	1	5	3	14	11	29	16	8	10
Downstream—Bkg	112	1	0	0	0	2	3	3	5	1	3	1
Downstream—Bkg	102	1	2	3	0	2	2	3	4	2	1	2
Downstream—Bkg	74	5	0	2	2	5	15	21	11	10	9	13
Downstream—Bkg	72	5	3	5	0	1	8	14	7	6	2	9
Downstream	25470	25760	19260	24690	12710	21140	25600	8605	3002	1602	637	443
Downstream	26180	26740	20150	25330	13180	21960	26370	9030	3102	1670	675	433
Downstream	25390	26060	19660	24280	12850	21130	25550	8897	3042	1679	652	461
Downstream	25880	26580	19950	25240	13020	21580	25910	8942	2944	1632	651	450
Downstream	25110	25630	19200	23980	12710	21060	25310	8664	2985	1607	625	455
Downstream	25310	25830	19530	24110	12820	20920	25070	8655	2961	1570	632	457
Downstream	25170	25510	19030	24000	12820	20490	25060	8542	2894	1535	618	379
Downstream	25600	25720	19500	24360	12920	21160	25200	8739	2858	1568	625	439
Downstream	24570	24710	18690	23480	12200	20290	24650	8439	2724	1602	603	398
Downstream	24310	24670	18420	23250	12330	20120	24410	8380	2839	1441	610	419
Downstream—Bkg	111	0	0	0	0	1	1	0	2	1	0	0
Downstream—Bkg	129	1	0	2	0	1	0	0	0	0	0	1
Downstream—Bkg	110	3	0	1	1	0	3	0	1	1	0	0
Downstream—Bkg	105	0	0	0	0	1	0	2	0	0	0	0
Downstream—Bkg	114	1	1	0	0	1	5	0	2	0	0	0
Avg. D_b	105.4	2.9	0.6	1.4	0.8	1.7	5.1	5.4	6.1	3.7	2.3	3.6
Std. Dev. D_b	18.93	3.70	1.07	1.65	1.62	1.42	5.51	7.37	8.75	5.40	3.43	5.02
$D_{b, ucl}$	118.94	5.54	1.37	2.58	1.96	2.71	9.04	10.67	12.36	7.56	4.76	7.19
$D_{b, ucl}/\text{Avg. } U_c^{**}$	0.005	0.000	0.000	0.000	0.000	0.000	0.000	0.001	0.004	0.005	0.007	0.017
R	0.991	0.988	0.993	0.993	0.995	0.996	0.990	0.981	1.021	0.985	0.931	0.999
Std. Dev. R	0.017	0.019	0.021	0.017	0.017	0.017	0.011	0.017	0.019	0.022	0.031	0.062
Std. Dev. $R \times t/n^{0.5} \dagger\dagger$	0.013	0.015	0.016	0.013	0.013	0.013	0.008	0.013	0.015	0.017	0.024	0.047

* For limits, see Section 10.6.2.4.

** For limits, see Section 10.6.2.3

† For limits, see Section 10.6.2.3.

†† For limits, see Section 10.6.2.1.

Figure B-3 Example correlation calculations for $n = 9$ sample sets in all particle size ranges. From run 1 of 5, 100% penetration test, ASHRAE RP-671 (Reference A1).

<i>i</i>	$U_{i,o,c}$	$D_{i,o,c}$	$U_{i,e,c}$	R_i	\bar{R}	δ_c	\bar{R}_{lcl}	\bar{R}_{ucl}	$\delta_c \times \frac{t}{\sqrt{i}}$
1	26290	25470	26340	0.967					
2	26390	26180	26235	0.998	0.982	0.022			
3	26080	25390	26160	0.971	0.978	0.017	0.936	1.021	0.042
4	26240	25880	25885	1.000	0.984	0.017	0.956	1.012	0.028
5	25530	25110	25565	0.982	0.983	0.015	0.965	1.002	0.019
6	25600	25310	25160	1.006	0.987	0.016	0.970	1.004	0.017
7	24720	25170	25135	1.001	0.989	0.016	0.975	1.004	0.015
8	25550	25600	25260	1.013	0.992	0.017	0.978	1.006	0.014
9	24970	24570	25080	0.980	0.991	0.016	0.978	1.004	0.013
10	25190	24310							

Figure B-4 Example correlation calculation for one particle size range with error evaluation at each step. From run 1 of 5, size range 1, 100% penetration tests, ASHRAE RP-671 (Reference A1).

B5.2 Penetration Calculations

B5.2.1 Figure B-5 shows an example penetration calculation for all particle size ranges. Here a fixed number of samples sets (nine) is used. The penetration ratios P are determined for each particle size range. The resulting penetration ratio error limits,

$$\sigma_c \times \frac{t}{\sqrt{n}}$$

are found for each particle size range and compared to the criteria in Equation 10.23 of Section 10.6.4.1. Also, the penetration ratio maximum background counts $D_{b,ucl}$, $U_{b,ucl}$ are calculated and compared to the criteria in Equation 10-24 of Section 10.6.4.2. Lastly, the penetration ratio minimum average upstream counts Avg. $U_{e,l}$ are calculated and compared to the criteria in Equation 10-25 of Section 10.6.4.3.

B5.2.2 Figure B-6 shows an example penetration calculation for a single particle size range. Here the penetration ratio error limit is calculated at the third measurement. The penetration ratio error limit is recalculated for each additional upstream and downstream measurement set. The test can be stopped when the penetration ratio error limit criterion of Section 10.6.4.1 is met.

B6. TEST SEQUENCE

The following tabulation of the test sequence steps may help to clarify the procedure:

Step	Air Cleaner	KCI Generator	Dust Feeder
1. Correlation ratio	None	On	Off
2. Resistance vs. airflow	In place	Off	Off
3. Initial PSE test	In place	On	Off
4. First dust loading	In place	Off	On
5. PSE test	In place	On	Off
6. Second dust loading	In place	Off	On
7. PSE test	In place	On	Off
8. Third dust loading	In place	Off	On
9. PSE test	In place	On	Off
10. Fourth dust loading	In place	Off	On
11. PSE test	In place	On	Off
12. Fifth dust loading	In place	Off	On
13. PSE test	In place	On	Off

Notes:

1. Each PSE test consists of the following:

a. Background counts	In place	Off	Off
b. Efficiency measurement	In place	On	Off
c. Background	In place	Off	Off
2. Prior to each dust loading, the duct airflow is turned off, the filter is installed, and the particle counters' inlet probes are capped. The duct airflow is then resumed.
3. After each dust loading, the duct airflow is turned off, the particle counters' inlet probes are uncapped, and the final filter is removed. The duct airflow is then resumed.

OPC Channel #	1	2	3	4	5	6	7	8	9	10	11	12
Geo. Mean Dia. (µm)	0.35	0.45	0.55	0.69	0.89	1.22	1.73	2.45	3.46	4.69	6.20	8.37
Upstream—Bkg	147	2	1	2	0	0	1	1	0	0	2	1
Upstream—Bkg	308	77	7	2	0	2	0	0	0	0	0	0
Upstream—Bkg	174	0	0	0	0	0	0	0	0	0	0	0
Upstream—Bkg	184	1	0	0	0	0	0	0	0	0	0	0
Upstream—Bkg	169	0	0	0	0	0	0	0	0	0	0	0
Upstream	21850	21770	16280	19670	10280	16830	21570	7618	2505	1376	547	321
Upstream	20820	20880	15270	18580	9843	16090	20680	7189	2479	1329	470	305
Upstream	21350	21040	15600	19160	9977	16500	20980	7314	2499	1332	511	332
Upstream	22630	22460	16420	20320	10660	17400	22360	7876	2620	1395	531	314
Upstream	21560	21210	15730	19260	10030	16800	21010	7348	2393	1270	536	291
Upstream	22240	21940	16060	19780	10390	17340	21530	7565	2557	1276	552	303
Upstream	22680	22170	16430	20180	10410	17620	22490	7546	2503	1362	546	324
Upstream	22590	21990	16550	19980	10450	17620	22360	7578	2576	1325	548	297
Upstream	23300	22980	16580	20660	10650	17730	22460	7706	2574	1329	498	300
Upstream	23850	23480	17180	21150	11180	18260	23480	8175	2675	1453	516	325
Upstream—Bkg	147	5	0	2	0	4	4	5	2	1	0	0
Upstream—Bkg	159	1	2	0	0	0	1	2	2	0	0	0
Upstream—Bkg	142	0	0	0	0	1	0	2	0	1	0	0
Upstream—Bkg	135	0	0	1	0	0	1	2	0	0	0	1
Upstream—Bkg	113	0	0	0	0	0	1	0	3	2	2	0
Avg. U_b	167.8	8.6	1	0.7	0	0.8	0.9	1.2	0.7	0.4	0.4	0.2
Std. Dev. U_b	53.38	24.08	2.21	0.95	0.00	1.32	1.20	1.62	1.16	0.70	0.84	0.42
$U_{b, ucl}$	205.98	25.83	2.58	1.38	0.00	1.74	1.76	2.36	1.53	0.90	1.00	0.50
Avg. U_t^*	22287	21992	16210	19874	10387	17219	21892	7591.5	2538.1	1344.7	525.5	311.2
$U_{b, ucl}/\text{Avg. } U_t^\dagger$	0.009	0.001	0.000	0.000	0.000	0.000	0.000	0.000	0.001	0.001	0.002	0.002
Downstream—Bkg	157	0	1	0	0	0	2	1	1	0	1	0
Downstream—Bkg	207	1	2	1	0	1	1	2	0	1	0	1
Downstream—Bkg	167	0	1	1	0	2	3	2	2	0	0	0
Downstream—Bkg	164	0	1	1	1	1	7	12	4	1	1	1
Downstream—Bkg	170	2	2	1	2	2	1	1	1	0	1	2
Downstream	17450	16070	11070	11840	4955	6220	3506	271	34	13	5	2
Downstream	17060	16080	10800	11540	4880	5969	3449	305	37	23	2	3
Downstream	17480	16480	10960	12040	5122	6288	3644	319	41	15	2	7
Downstream	18640	17170	11590	12550	5264	6379	3813	303	42	11	6	3
Downstream	17180	15760	10770	11540	4859	6053	3497	272	24	10	7	2
Downstream	18350	16740	11440	12200	5134	6251	3607	317	39	14	3	5
Downstream	18220	16780	11300	12000	5091	6239	3608	298	40	11	6	3
Downstream	18500	17190	11590	12300	5180	6442	3720	302	42	15	6	3
Downstream	18970	17780	12170	12620	5470	6745	3851	303	53	17	9	2
Downstream	19450	18030	12380	13330	5667	6940	3995	263	37	13	3	1
Downstream—Bkg	189	14	1	0	0	0	0	0	0	0	0	0
Downstream—Bkg	138	0	1	0	0	0	0	0	0	0	0	0
Downstream—Bkg	161	0	0	0	0	1	0	2	1	2	1	0
Downstream—Bkg	136	0	0	0	0	0	1	0	0	0	0	0
Downstream—Bkg	139	1	0	0	0	0	0	3	1	1	1	0
Avg. D_b	162.8	1.8	0.9	0.4	0.3	0.7	1.5	2.3	1	0.5	0.5	0.4
Std. Dev. D_b	22.72	4.34	0.74	0.52	0.67	0.82	2.17	3.56	1.25	0.71	0.53	0.70
$D_{b, ucl}$	179.05	4.91	1.43	0.77	0.78	1.29	3.05	4.85	1.89	1.01	0.88	0.90
$D_{b, ucl}/\text{Avg. } U_t^{**}$	0.008	0.000	0.000	0.000	0.000	0.000	0.000	0.001	0.001	0.001	0.002	0.003
R	0.991	0.988	0.993	0.993	0.995	0.996	0.990	0.981	1.021	0.985	0.931	0.999
Std. Dev. R	0.808	0.761	0.699	0.609	0.493	0.366	0.166	0.039	0.015	0.010	0.009	0.009
Std. Dev. $R/n^{0.5}$	0.815	0.770	0.704	0.613	0.496	0.367	0.168	0.040	0.015	0.010	0.009	0.009
Std. Dev. P_o	0.017	0.015	0.015	0.012	0.009	0.009	0.004	0.002	0.003	0.003	0.005	0.005
Std. Dev. P	0.017	0.019	0.021	0.017	0.017	0.017	0.011	0.017	0.019	0.022	0.031	0.062
Std. Dev. P	0.022	0.021	0.021	0.017	0.012	0.011	0.005	0.002	0.003	0.003	0.005	0.005
Std. Dev. $P \times t/n^{0.5} \dagger\dagger$	0.017	0.016	0.016	0.013	0.010	0.008	0.003	0.002	0.002	0.002	0.004	0.004

* For limits, see Section 10.6.4.4.

** For limits, see Section 10.6.4.2.

† For limits, see Section 10.6.4.2.

†† For limits, see Section 10.6.4.1.

Figure B-5 Example penetration calculations for $n = 9$ sample sets in all particle size ranges. From run 1 of 3, pleated paper filter tests, ASHRAE RP-671 (Reference A1).

i	$U_{i,o,t}$	$D_{i,o,t}$	$U_{i,e,t}$	$P_{i,o}$	\bar{P}_o	\bar{P}	δ_t	d	\bar{P}_{lcl}	\bar{P}_{ucl}	$\delta_c \times \frac{t}{\sqrt{n}}$
1	21850	17450	21335	0.818							
2	20820	17060	21085	0.809	0.814	0.820	0.006	0.015			
3	21350	17480	21990	0.795	0.807	0.814	0.012	0.018	0.762	0.836	0.045
4	22630	18640	22095	0.844	0.816	0.823	0.020	0.025	0.777	0.849	0.039
5	21560	17180	21900	0.784	0.810	0.816	0.023	0.027	0.777	0.838	0.033
6	22240	18350	22460	0.817	0.811	0.817	0.021	0.025	0.785	0.833	0.026
7	22680	18220	22635	0.805	0.810	0.817	0.019	0.023	0.789	0.828	0.022
8	22590	18500	22945	0.806	0.810	0.816	0.018	0.022	0.791	0.824	0.019
9	23300	18970	23575	0.805	0.809	0.816	0.017	0.022	0.793	0.822	0.017
10	23850	19450									

Figure B-6 Example penetration calculation for one particle size range with error evaluation at each step, where $\delta_o = 0.017$ and $R = 0.992$. From run 1 of 3, size range 1, pleated paper filter tests, ASHRAE RP-671 (Reference A1).

(This appendix is not part of this standard. It is merely informative and does not contain requirements necessary for conformance to the standard. It has not been processed according to the ANSI requirements for a standard and may contain material that has not been subject to public review or a consensus process. Unresolved objections on informative material are not offered the right to appeal at ASHRAE or ANSI.)

INFORMATIVE APPENDIX C HOW TO READ A TEST REPORT

This appendix is meant to provide background information about the test report and explanations in layman's terms for users (building owners, installers, and design engineers).

C1. BACKGROUND

C1.1 ASHRAE does not actually test air cleaners or determine their performance but only promulgates the test procedure used by manufacturers and independent testing laboratories.

C1.2 Air-cleaner testing in a laboratory is intended to help the user compare the performance of different types of air cleaners. Testing attempts to simulate the performance of air cleaners in real-life operation but cannot duplicate field conditions. Field conditions vary from location to location. The reporting values obtained in accordance with this standard cannot be used by themselves to predict the air cleanliness of a specific ventilated space or the service life of installed air cleaners.

C1.3 Testing accelerates the life experience of an air cleaner, and accelerated use is different from normal use. The ASHRAE test involves concentrations and compositions that are almost certain to be different from those the air cleaner will encounter when installed in a system. Also, the airflow rate, final resistance, and temperature and humidity level of the air may be different in the testing laboratory from those on the job.

C1.4 Laboratory accuracy is expected of the instrumentation used in testing to the standard. However, this does not mean that the tested filter will perform with laboratory accuracy on an installed job.

C2. READING A TEST REPORT

C2.1 The summary section of a sample performance report on a typical extended-surface media filter is shown in Figures C-1, C-2, and C-3. The circled numbers refer to the explanations that follow.

1. The test method should be in accordance with the latest edition of the ASHRAE standard.
2. These sections are helpful to trace the test laboratory, test owner, and test specimen.
3. This information is important for identification. Upon request, independent test laboratories will verify data with users and identify any tampering with the results.
4. This information is useful because different types of detecting devices may give differing readings. Good calibration is most necessary.
5. Manufacturers' catalog data are not required by the standard, but if such data are included in the test report, it will

help the user compare published data and actual performance.

6. The test airflow rate is specified by the manufacturer and generally depends on the filter size (height, width, and depth), media area, and construction. The airflow rate must be between 0.22 and 1.4 m³/s (472 and 2990 cfm) and be selected from Section 8.1.
7. Device manufacturers must specify the final resistance for testing using Table 12-1 values as minimums.
8. The physical description must match the filter being considered. This part is very important because there are many filters with the same name and a different appearance (fewer pockets, longer pockets, etc.).
9. The test airflow rate and net effective media area may be used to calculate media velocity:

$$\text{Media velocity, m/s (fpm)} = \frac{\text{Airflow rate, m}^3/\text{s (cfm)}}{\text{Effective media area, m}^2(\text{ft}^2)}$$

10. Note that the performance of a manufactured filter will usually be very different from that of a flat sheet of the media used to construct the filter.
11. The initial resistance is the resistance to airflow of the filter at the test airflow rate. Depending on the design and construction of the filter, initial resistance may or may not indicate life expectancy.
12. These minimum averages help to define the minimum performance of the device in removing particles of various sizes. They are not full averages.
13. The MERV is based on the minimum PSEs and Table 12-1. The reporting value helps the user select an air cleaner but does not reflect the total behavior of the device.
14. This curve shows the resistance of the clean filter over the prescribed range of face velocities.
15. These curves show the PSE after loading with incremental amounts of dust.
16. This curve shows the minimum values of PSE during the test. Refer to Informative Appendix D for examples of the use of this curve.
17. The dust-holding capacity presents the total weight of synthetic loading dust captured by the air-cleaning device over all of the incremental dust loading steps. This value should not be used to calculate the expected life of the device in use.
18. The average dust arrestance presents the ability of the filter to remove loading dust from test air. This is measured and reported only for air-cleaning devices with efficiencies less than 20% in the size range of 3.0 to 10.0 μm .
19. The release rate gives an indication of filter shedding.
20. This curve shows the resistance vs. synthetic loading dust fed (for air-cleaning devices with efficiencies less than 20% in the size range of 3.0 to 10.0 μm).

ASHRAE Std. 52.2 Air Cleaner Performance Report Summary

① (This report applies to the tested device only)

Laboratory Data ③

Report No. 99-392 Test No. 99-1798 Date DEC. 12, 1999

Test laboratory INDEPENDENT TEST LABS, INC.

Operator T. SMITH Supervisor G. SUPER

Particle counter(s): Brand COUNTALL Model 226/80

④ **Device Manufacturer's Data** ② ③

Manufacturer FILTERMAKER, INC.

Product name FLO-RITE Model 12

Test requested by FILTER SALES CO.

Sample obtained from OPEN MARKET ⑤

Catalog rating: Airflow rate 1.18 m³/s Initial press. drop 53 Pa

Specified test conditions: Airflow rate 1.18 m³/s ⑥

Final pressure drop 250 Pa ⑦ Face velocity 3.2 m/s

Device Description ⑧

Dimensions: height 590 mm width 590 mm depth 560 mm

Generic name BAG FILTER Media type SYN. NONWOVEN POLYESTER

Effective media area 3.5 m² ⑨ Media color YELLOW

Amount and type of adhesive NONE

Other attributes 5 POCKETS

Test Conditions

Airflow rate 1.18 m³/s Temperature 22°C RH 50%

Test aerosol type KCl

Final pressure drop 250 Pa Face velocity 3.2 m/s

Remarks NONE

Resistance Test Results

Initial resistance 57 Pa ⑩ Final resistance 250 Pa

Minimum Efficiency Reporting Data

Composite average efficiencies E₁ 13% E₂ 60% E₃ 87% ⑪

Air cleaner average Arrestance N/A ⑰

Minimum efficiency reporting value (MERV) for the device:

Dust Holding Capacity (g) 693 ⑱ MERV 10 @ 1.18 ⑫

Figure C-1 Sample summary air-cleaner performance report, Page 1.

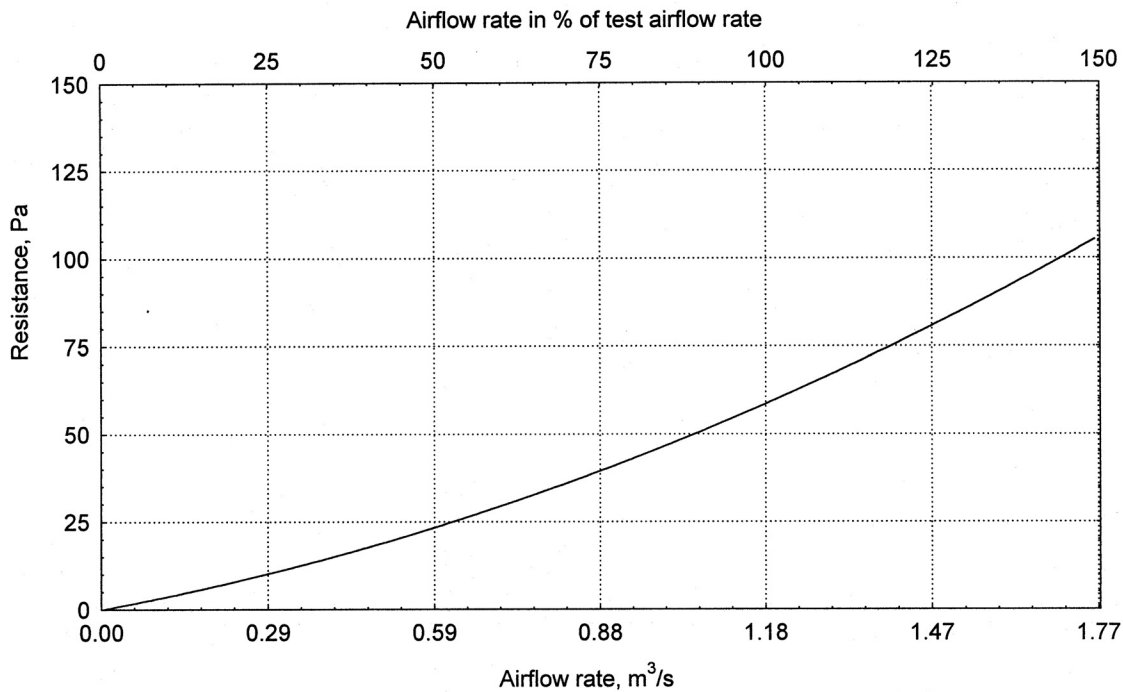

(a)

13

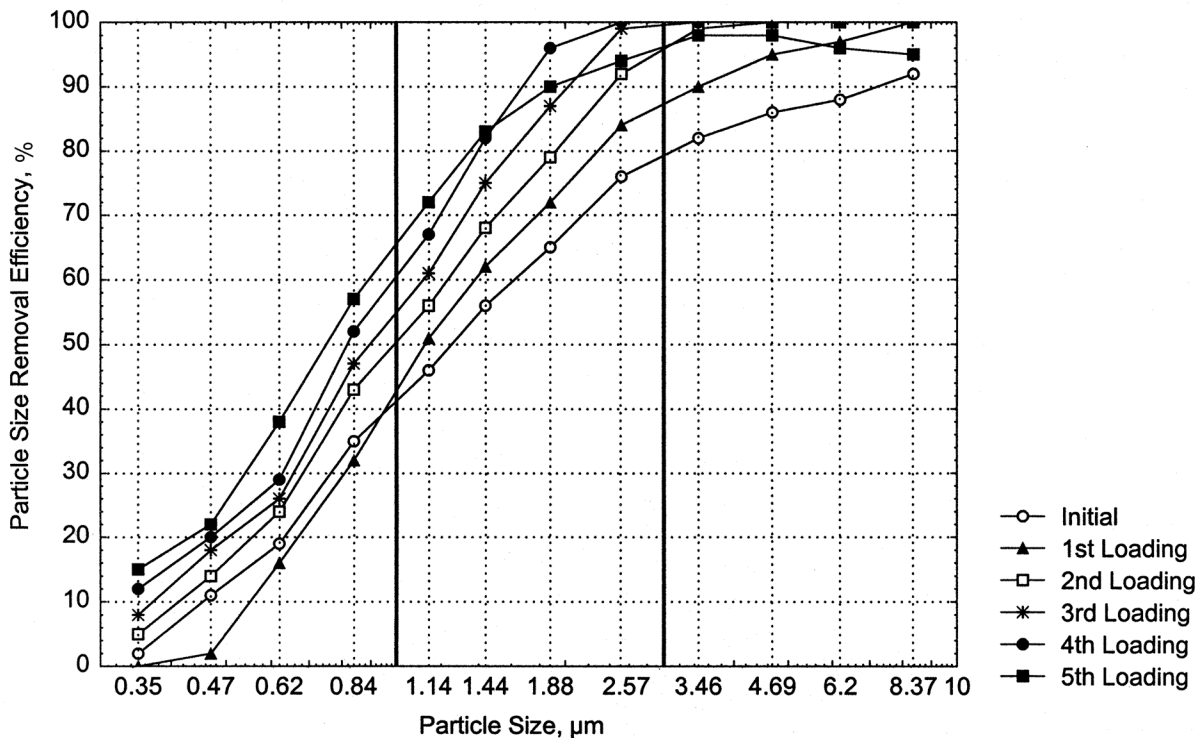

(b)

14

Figure C-2 Sample air-cleaner performance report summary, Page 2.

(a) Resistance of clean device vs. airflow.

(b) PSE after incremental dust loading.

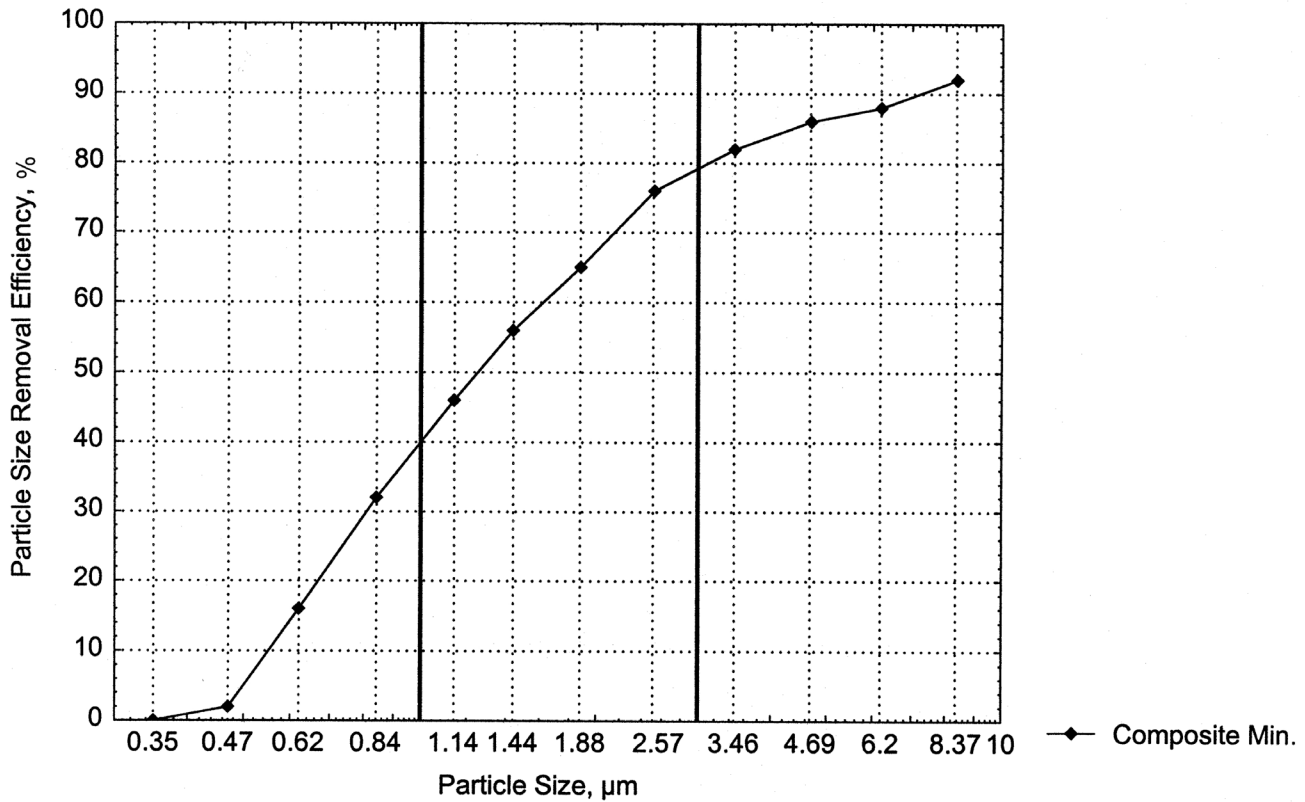

15

Figure C-3 Sample air-cleaner performance report summary, Page 3.
 —Composite minimum efficiency curve.

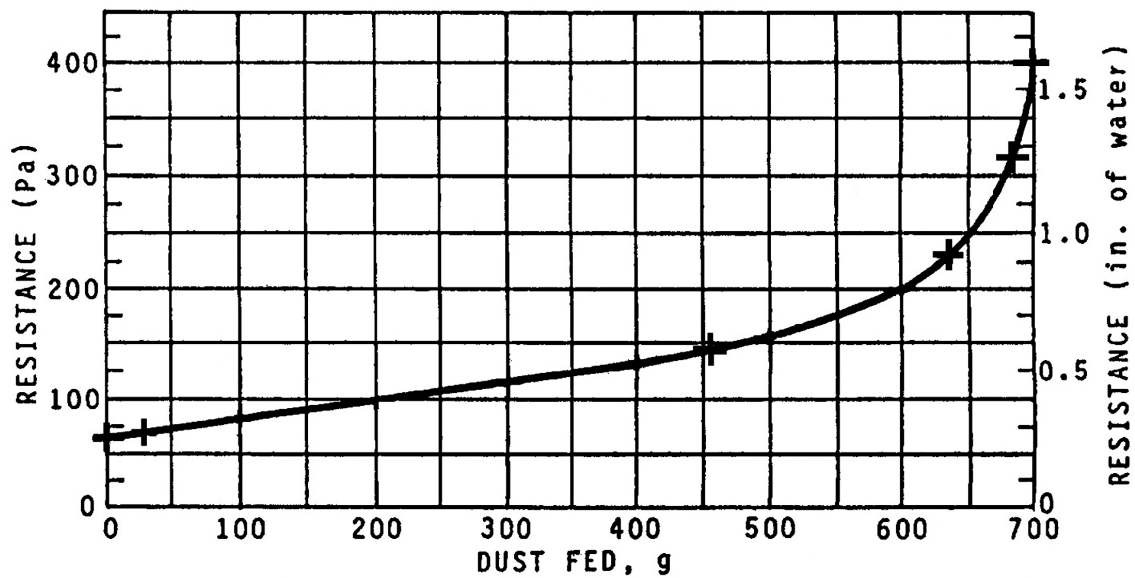

18

Figure C-4 Sample air-cleaner report summary, Page 3.
 —Resistance vs. Synthetic Loading Dust Fed graph ONLY for air-cleaning devices with efficiencies less than 20% in the size range of 3.0 to 10.0 µm).

(This appendix is not part of this standard. It is merely informative and does not contain requirements necessary for conformance to the standard. It has not been processed according to the ANSI requirements for a standard and may contain material that has not been subject to public review or a consensus process. Unresolved objections on informative material are not offered the right to appeal at ASHRAE or ANSI.)

INFORMATIVE APPENDIX D MINIMUM EFFICIENCY REPORTING GUIDANCE

D1. GENERAL RECOMMENDATIONS

The purpose of this appendix is to provide guidance in using the system and show some examples of MERVs.

D1.1 Removal efficiency vs. particle size tests of an air cleaner as it is loaded with dust yields a set of curves that may be inconvenient to use. This reporting system simplifies the selection of air cleaners by providing a single particle size removal efficiency reporting value for specification purposes.

D1.2 Any reporting system is a compromise and can never reflect all the performance parameters of an air cleaner. Manufacturer data should be consulted whenever specific removal performance is desired.

D2. EXAMPLES

Examples of typical minimum efficiency curves are shown in Figure D-1. Each curve is the minimum performance of the air cleaner from the initial test of the clean device to the test at its final loading stage. It will be helpful to have Table 12-1 readily available for reference when reviewing these curves and the method.

D2.1 “Filter A”—The MERV for this air cleaner is MERV14 at 0.93. This minimum performance curve is typical of a media air cleaner currently marketed as a 90% to 95% dust spot filter when tested at 0.93 m³/s (1970 cfm). The minimum efficiencies for the particle size ranges must be calculated to report the filter. The PSEs are as follows:

Range	Size, μm	PSE in Range,%	Average PSE,%
1	0.30 to 1.0	74, 82, 87, 92	84
2	1.0 to 3.0	96, 98, 99, 100	98
3	3.0 to 10	100, 100, 100, 100	100

The average efficiencies in Ranges 2 and 3 are above the 90% minimum shown in Table 12-1 for a filter in MERV Group 1 to 4. According to Table 12-1, this filter, with an average minimum efficiency in Range 1 of 84%, is reported as MERV14 at 0.93.

D2.2 “Filter B”—The reporting value for this air cleaner is MERV11 at 0.93. This minimum performance curve is typical of a media air cleaner currently marketed as a 60% to 65% dust spot filter when tested at 0.93 m³/s (1970 cfm). The range efficiencies are calculated as follows:

Range	Size, μm	PSE in Range,%	Average PSE,%
1	0.30 to 1.0	18, 28, 38, 47	33
2	1.0 to 3.0	58, 72, 84, 96	78
3	3.0 to 10	98, 99, 99, 99	99

The average efficiency in Range 3 is above the 85% and 90% minimums shown in Table 12-1 for the MERV Group 9 to 12 and MERV Group 13 to 16 categories, respectively. However, the filter is categorized in the MERV Group 9 to 12

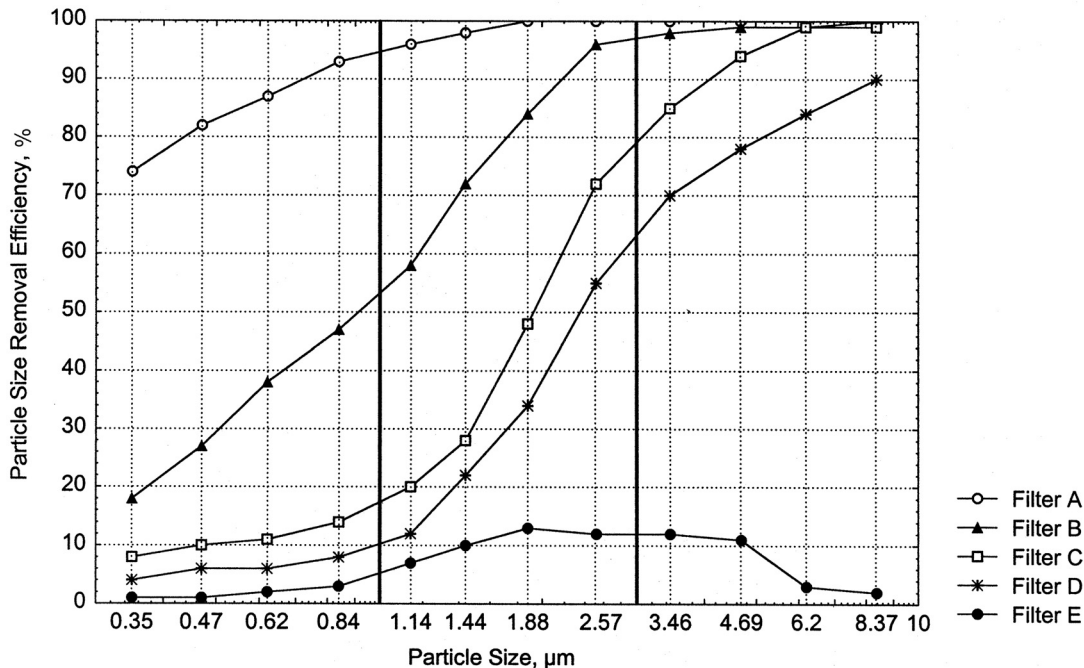

Figure D-1 Typical minimum efficiency curves.

area since the average efficiency in Range 2 is below the 90% minimum requirement for the MERV Group 13 to 16 category. The average efficiency in Range 1 is not used for reporting. Based on the average efficiency of 78% in Range 2, the filter is reported as MERV11 at 0.93.

D2.3 “Filter C”—The reporting value for this air cleaner is MERV9 at 0.93. This minimum performance curve is typical of a media air cleaner currently marketed as a 40% to 45% dust spot filter when tested at 0.93 m³/s (1970 cfm). As in the examples above, the range efficiencies are calculated as follows:

Range	Size	PSE in Range,%	Average PSE,%
1	0.30 to 1.0	8, 10, 11, 14	11
2	1.0 to 3.0	20, 28, 48, 72	42
3	3.0 to 10	85, 94, 98, 99	94

The average efficiency in Range 3 is above the 85% and 90% minimums shown in Table 12-1 for the MERV Group 9 to 12 and MERV Group 13 to 16 categories, respectively. The filter is categorized in the MERV Group 9 to 12 area because the average efficiency in Range 2 is below the 90% minimum requirement for the MERV Group 13 to 16 category. The average efficiency in Range 1 is not used for reporting. Based on the average efficiency of 42% in Range 2, this filter is reported as MERV9 at 0.93.

D2.4 “Filter D”—The reporting value for this air cleaner is MERV8 at 0.93. This minimum performance curve is typical of a media air cleaner currently marketed as a 25% to 30% dust spot filter when tested at 0.93 m³/s (1970 cfm). The range efficiencies are calculated as follows:

Range	Size	PSE in Range,%	Average PSE,%
1	0.30 to 1.0	5, 6, 6, 8	6
2	1.0 to 3.0	12, 22, 33, 55	31
3	3.0 to 10	70, 78, 84, 90	81

The average efficiency in Range 3 is in the 80% to 85% range shown in Table 12-1 for the MERV Group 10 category. However, the E2 value is above the 20% required for MERV 8 and below the 35% required for MERV 9. Thus, the MERV of this filter is reported as MERV 8 at 0.93.

D2.5 “Filter E”—The dust-loading test in this standard cannot be used to report this air cleaner. This minimum performance curve is typical of a media air cleaner currently marketed as a “furnace” filter. The average efficiencies are below the 20% minimum requirement shown in Table 12-1 for MERV Group 5 to 8:

Range	Size, μm	PSE in Range,%	Average PSE,%
1	0.30 to 1.0	1, 1, 2, 3	2
2	1.0 to 3.0	8, 10, 13, 12	11
3	3.0 to 10	12, 11, 4, 2	7

The filter is classified as MERV Group 1 to 4 and must be tested in accordance with the arrestance method outlined in Section 10.7 of this standard. The air cleaner can then be reported in accordance with Table 12-1 using the average arrestance value.

D3. CONCLUSIONS

In most cases, comparisons of air cleaners of similar type and material will yield good relationships between laboratory and field conditions. However, the user must be aware that the tests are made under laboratory conditions using synthetic dust for loading. The synthetic dust used to load the test air cleaner is not representative of all atmospheric particulates, and, thus, tests on some types of air cleaners may be affected favorably or otherwise.

(This appendix is not part of this standard. It is merely informative and does not contain requirements necessary for conformance to the standard. It has not been processed according to the ANSI requirements for a standard and may contain material that has not been subject to public review or a consensus process. Unresolved objections on informative material are not offered the right to appeal at ASHRAE or ANSI.)

INFORMATIVE APPENDIX E CROSS-REFERENCE AND APPLICATION GUIDELINES

E1. INTRODUCTION

E1.1 The purpose of this appendix is to provide an approximate cross reference of Standard 52.1-1992 reporting methods (arrestance and atmospheric dust-spot efficiency) to the air-cleaner minimum efficiency reporting system outlined in Section 12. A corollary purpose is to provide application guidance to the user and HVAC system designer. To do this most effectively, HEPA/ULPA filters have been added to the reporting system. HEPA/ULPA filters have been assigned MERVs based on their performance in accordance with Institute of Environmental Sciences and Technology (IEST) standards. Table E-1 combines all of the parameters into a single reference covering most general ventilation air-cleaner types and applications.

E1.2 A single performance measurement system cannot be applied precisely to all types and styles of air cleaners. Each air cleaner has unique characteristics that change during its useful life. Also, the particle size efficiency test method in this standard does not eliminate the need for dioctyl phthalate (DOP) penetration and arrestance testing. This new reporting system may, however, eventually replace the arrestance and atmospheric dust-spot and DOP efficiency reporting values as performance references.

E1.3 Typical contaminants listed in Table E-1, “Application Guidelines,” appear within the general reporting group that removes the smallest known size of that particular contaminant. The order in which they are written has no significance, nor is the list complete.

E1.4 Typical applications and typical air-cleaner types listed are intended to show where and what type air cleaner is traditionally used. The order in which they are written has no significance, nor is the list complete. Traditional use may not represent the optimum choice, so using the table as a selection guide is not appropriate when a specific performance requirement is needed. Consultation with an air-cleaner specialist is then advisable, and manufacturer’s performance curves should be reviewed.

E1.5 Some knowledge of how air cleaners work and common sense will also help the user achieve satisfactory results. Air-cleaner performance varies from the time it is first installed until it reaches the end of its service life. Generally, the longer a media-type filter is in service, the better it performs. The accumulation of contaminants begins to close the porous openings and, therefore, the filter is able to intercept particles of smaller size. However, there are exceptions that vary with different styles of media-type filters.

E1.6 Some air cleaners, particularly those in the lower part of the minimum efficiency reporting values, may begin to shed some of the collected contaminants after varying lengths of service life. Testing with standardized synthetic loading dust attempts to predict this occurrence, but this will rarely, if ever, duplicate performance on atmospheric dust.

E2. AIR-CLEANER EFFECTIVENESS

Three factors determine the effectiveness of an air cleaner to treat the air in an occupied space: air-cleaner efficiency, the amount of air being filtered, and the path that the clean air follows after it leaves the filter.

E2.1 As an example of the interaction of air-cleaner efficiency and airflow rate, portable self-contained (fan and filter) air-cleaner effectiveness is often measured by the clean air delivery rate (CADR), which is the combined effect of how much air actually is moved through the filter and the efficiency of the filter. A high-efficiency air filter in an air cleaner with a low airflow rate can have a lower CADR than one with a lower MERV air filter but higher airflow volume.

E2.2 An airflow path considered best would be one that would enter the space where the cleanest air is required, flow without turbulence through 100% of the space toward the point where cleanliness is least important (perhaps near the floor), and then return to the air cleaner. These ideal conditions can rarely be met, so most installations must be a compromise between what is desired and what is practical.

E2.3 Air cleaners are tested under ideal laboratory conditions where care is taken to prevent leakage of air around them. Totally leak-free hardware is unusual in HVAC equipment, so air cleaners rarely perform to the same degree of effectiveness under field conditions. Only extreme care in finding and sealing all the leak paths in the hardware and in ductwork between the filter and the fan will ensure full performance of the air cleaner.

E2.4 Table E-1, “Application Guidelines” covers particulate contamination control only, as does this standard. Gaseous contaminant control is also important in many systems but is not addressed in this guideline.

Table E-1 Application Guidelines

Std. 52.2 Minimum Efficiency Reporting Value (MERV)	Application Guidelines		
	Typical Controlled Contaminant	Typical Applications and Limitations	Typical Air Filter/Cleaner Type
16	0.30 to 1.0 µm Particle Size All bacteria	Hospital inpatient care General surgery	Bag Filters Nonsupported (flexible) microfine fiberglass or synthetic media. 300 to 900 mm (12 to 36 in.) deep, 6 to 12 pockets.
15	Most tobacco smoke Droplet nuclei (sneeze)	Smoking lounges Superior commercial buildings	Box Filters Rigid style cartridge filters 150 to 300 mm (6 to 12 in.) deep may use lofted (air laid) or paper (wet laid) media.
14	Cooking oil Most smoke		
13	Insecticide dust Copier toner Most face powder Most paint pigments		
12	1.0 to 3.0 µm Particle Size Legionella	Superior residential Better commercial buildings	Bag Filters Nonsupported (flexible) microfine fiberglass or synthetic media. 300 to 900 mm (12 to 36 in.) deep, 6 to 12 pockets.
11	Humidifier dust Lead dust	Hospital laboratories	Box Filters Rigid style cartridge filters 150 to 300 mm (6 to 12 in.) deep may use lofted (air laid) or paper (wet laid) media.
10	Milled flour Coal dust		
9	Auto emissions Nebulizer drops Welding fumes		
8	3.0 to 10.0 µm Particle Size Mold	Commercial buildings Better residential	Pleated Filters Disposable, extended surface, 25 to 125 mm (1 to 5 in.) thick with cotton-polyester blend media, cardboard frame.
7	Spores Hair spray	Industrial workplaces Paint booth inlet air	Cartridge Filters Graded density viscous coated cube or pocket filters, synthetic media.
6	Fabric protector Dusting aids		Throwaway Disposable synthetic media panel filters.
5	Cement dust Pudding mix Snuff Powdered milk		
4	>10.0 µm Particle Size Pollen	Minimum filtration Residential	Throwaway Disposable fiberglass or synthetic panel filters
3	Spanish moss Dust mites	Window air conditioners	Washable Aluminum mesh, latex coated animal hair, or foam rubber panel filters
2	Sanding dust Spray paint dust		Electrostatic Self charging (passive) woven polycarbonate panel filter
1	Textile fibers Carpet fibers		

Note: A MERV for other than HEPA/ULPA filters also includes a test airflow rate, but it is not shown here because it has no significance for the purposes of this table.

(This appendix is not part of this standard. It is merely informative and does not contain requirements necessary for conformance to the standard. It has not been processed according to the ANSI requirements for a standard and may contain material that has not been subject to public review or a consensus process. Unresolved objections on informative material are not offered the right to appeal at ASHRAE or ANSI.)

INFORMATIVE APPENDIX F ACRONYMS AND CONVERSION FORMULAE

F1. ACRONYMS

CADR	Clean air delivery rate
IAQ	Indoor air quality
IEST	Institute of Environmental Sciences and Technology
OPC	Optical particle counter

For the meanings of other acronyms, refer to Section 3.2.

F2. CONVERSION FORMULAE

The following units and conversions may be useful in using this standard.

1 m	≈	3.2808 ft
1 m ²	≈	10.764 ft ²
1 m ³	≈	35.315 ft ³
1 m/s	≈	196.85 fpm
1 m ³ /s	≈	2118.9 cfm
1 m ³ /s	=	1000 L/s
1 m ³ /min	≈	35.315 cfm
1 m ³ /h	≈	0.5886 cfm
1 cm ³ /s	≈	0.00212 cfm
1 Pa	≈	0.00402 in. of water

A converted value is no more precise than the original value. The final value should be rounded off to the same number of significant figures as the original value.

(This appendix is not part of this standard. It is merely informative and does not contain requirements necessary for conformance to the standard. It has not been processed according to the ANSI requirements for a standard and may contain material that has not been subject to public review or a consensus process. Unresolved objections on informative material are not offered the right to appeal at ASHRAE or ANSI.)

INFORMATIVE APPENDIX G INFORMATIVE REFERENCES

The following references are cited for information only. Normative references are located in Section 13 of the standard.

1. ASHRAE. 1991. *ASHRAE Terminology of Heating, Ventilation, Air Conditioning, & Refrigeration*, Second Edition. Atlanta: ASHRAE.
2. See normative references in Section 13.
3. Riehl, J., V.R. Dileep, N.K. Anand, and A.R. McFarland. 1996. *DEPOSITION 4.0: An Illustrated User's Guide*. Report 8836/07/96, Aerosol Technology Laboratory, Department of Mechanical Engineering, Texas A&M University, College Station, TX.
4. See normative references in Section 13.
5. See normative references in Section 13.
6. See normative references in Section 13.
7. See normative references in Section 13.
8. See normative references in Section 13.
9. See normative references in Section 13.
10. ASME. 1989. ASME Standard MFC-3M, *Measurement of Fluid Flow in Pipes Using Orifices, Nozzles and Venturi*. New York: American Society of Mechanical Engineers.
11. See normative references in Section 13.
12. See normative references in Section 13.

(This appendix is not part of this standard. It is merely informative and does not contain requirements necessary for conformance to the standard. It has not been processed according to the ANSI requirements for a standard and may contain material that has not been subject to public review or a consensus process. Unresolved objectors on informative material are not offered the right to appeal at ASHRAE or ANSI.)

**INFORMATIVE APPENDIX H
ADDENDA DESCRIPTION INFORMATION**

ANSI/ASHRAE Standard 52.2-2017 incorporates ANSI/ASHRAE Standard 52.2-20012 and Addenda a, b, c, d, e, f, g, and i to ANSI/ASHRAE Standard 52.2-2012. Table H-1 lists the addendum and describes the way in which the standard is affected by the change. It also lists the ASHRAE and ANSI approval dates for the addendum.

Table H-1 Addenda to ANSI/ASHRAE Standard 52.2-2012

Addendum	Sections Affected	Description of Changes*	ASHRAE Standards Committee Approval	ASHRAE BOD Approval	ANSI Approval
a	12, Appendix D, Appendix J	Replaces Table 12-1, modifies language in D2.4 to correspond to updated Table 12-1, and replaces Table J-2.	12/30/14	12/30/14	12/31/14
b	3.1, 10.1, 10.4.2, 10.6.3.2, 10.6.3.3, 10.7.3, 11, C2.1	Adds new definition, adds symbol, modifies language in 10.4.2, clarifies equation in 10.6.3.2, replaces equation in 10.6.3.3, revises 10.7.3 and adds new section 10.7.3.3, adds language to 11.2, revises Figure 11-1d, adds language to C2.1.	6/28/14	7/2/14	7/31/14
c	3.1, 4.6, 5.1, 5.15, 5.16, 10.6.2, 10.6.4	Adds new definition, adds new language to Section 4.6, adds new Sections 5.15 and 5.16, adds new language to Section 10.6.2.5, and corrects numbering in Section 10.6.4.1.	7/1/15	NA	7/28/15
d	4.2.3, 4.3.2, Appendix J	Revises relative humidity language in 4.2.3, 4.3.2, and J10.8.	6/28/14	7/2/14	7/3/14
e	12.5	Adds new Section 12.5.	2/29/16	NA	3/1/16
f	11.3 and Figure 11-1d	Modifies language in Section 11.3 and makes changes to Figure 11-1d.	2/29/16	NA	3/1/16
g	Appendix K	Adds new Appendix K.	12/30/16	NA	12/30/16
i	13, Appendix G, 6.2	Removes a reference and adds new reference to Section 13, modifies language in Section 6.2, removes footnote 38.	12/30/16	NA	12/30/16

NOTE

Approved addenda, errata, or interpretations for this standard can be downloaded free of charge from the ASHRAE Web site at www.ashrae.org/technology.

(This appendix is not part of this standard. It is merely informative and does not contain requirements necessary for conformance to the standard. It has not been processed according to the ANSI requirements for a standard and has not been subject to public review or a consensus process. Unresolved objectors on informative material are not offered the right to appeal at ASHRAE or ANSI.)

**INFORMATIVE APPENDIX I
(INTENTIONALLY LEFT BLANK)**

(This appendix is not part of this standard. It is merely informative and does not contain requirements necessary for conformance to the standard. It has not been processed according to the ANSI requirements for a standard and has not been subject to public review or a consensus process. Unresolved objectors on informative material are not offered the right to appeal at ASHRAE or ANSI.)

INFORMATIVE APPENDIX J OPTIONAL METHOD OF CONDITIONING A FILTER USING FINE KCl PARTICLES TO DEMONSTRATE EFFICIENCY LOSS THAT MIGHT BE REALIZED IN FIELD APPLICATIONS

J1. PURPOSE OF OPTIONAL TEST

Appendix J presents a conditioning procedure to determine the magnitude of the efficiency loss a filter may realize in field applications. This procedure is a separate test from that described in Section 10.7.1.2(b). For any particular type or model of filter, the test described in the body of the standard must be used. If desired, both tests may be used; however, the same test filter may not be tested with both methods. When the test in Appendix J is used, the data output obtained from the efficiency test procedure after the KCl conditioning step is referred to as MERV-A, as defined in Section J2.2. The data output value is thus differentiated from the MERV value that is the data output of the test without the KCl conditioning.

The conditioning step described herein is representative of the best available knowledge of real-life filter efficiency degradation at the time of the publication of this procedure. Changes in filtration performance are environment dependent and, therefore, filters may or may not degrade to the conditioned efficiencies described in this document. For this reason, the results in this appendix may be used to compare filters as described in the foreword to Standard 52.2 (see section titled “Not an Application Standard”).

The goal of this appendix is to provide an optional conditioning method of test, gather data using this method, and validate this method to achieve consensus for possible future incorporation into the body of the standard. This procedure is being included as an option to the test method so that those concerned about a possible drop in filtration efficiency have a recognized test method to predict the magnitude of the efficiency loss. This standard is under continuous maintenance, and the committee welcomes continuous maintenance proposals addressing means to improve the method.

J2. DEFINITIONS AND ACRONYMS

J2.1 Definitions to be used in addition to those listed in Section 3 of the standard are as follows:

condensation particle counter (CPC): an instrument used to measure the concentration of submicrometer aerosol particles. Also called a *condensation nucleus counter (CNC)*.

conditioning aerosol: a submicrometer solid-phase potassium chloride aerosol used to reproduce the falloff in efficiency that electret filters may experience in real-life applications.

CT: for the conditioning aerosol, the product of the in-duct aerosol concentration C measured with the CPC and the exposure time T .

Laskin generator: a nozzle that uses a source of compressed air as part of a system to generate a polydispersed aerosol from a liquid. **Note:** A Laskin generator is shown in *NSF Standard 49: Class II (Laminar Flow) Biosafety Cabinetry*.

J2.2 Acronyms to be used in addition to those listed in Section 3 of the standard are as follows:

A_{avg-A} = average value of the arrestances made on the device during loading test when Appendix J conditioning is used.

DHC-A = the total weight of the synthetic loading dust captured when Appendix J conditioning is used.

MERV-A #-A = minimum efficiency reporting value according to Appendix J, where # represents the numeric value from Table J-2.

J3. TEST APPARATUS FOR CONDITIONING AEROSOL IN ADDITION TO THE TEST APPARATUS REQUIRED IN SECTION 4, “TEST APPARATUS”

J3.1 Condensation Particle Counter. The in-duct concentration of the conditioning aerosol shall be measured with a CPC having a minimum 50% counting efficiency at $0.02 \mu\text{m}$. The CPC shall have a concentration limit of $\geq 500,000 \text{ cm}^{-3}$. The CPC shall not be operated above its concentration limit.

J3.2 Laskin Generator. The conditioning aerosol shall be generated using one or more Laskin generators. The aerosol output of the Laskin generators is not required to be passed through a charge neutralizer. The nozzles shall be operated at air pressures of 20 to 60 psig. The Laskin generators shall be operated with an aqueous solution of KCl in water prepared to a ratio of 1.00 g of reagent grade KCl for each 1.00 L of distilled or filtered deionized water. The compressed air line supplying the Laskin generator shall be equipped with devices for the removal of oil and water and have a high-efficiency particle filter (99.97% @ $0.3 \mu\text{m}$ or better) installed near the Laskin generators. The conditioning aerosol shall be injected between the inlet filter bank (item 3 of Figure 4-1) and the upstream mixing orifice (item 9 of Figure 4-1).

J3.3 Separate Duct for Conditioning Step. The use of a separate duct for the conditioning portion of the test is acceptable as long as the conditioning duct meets the following criteria:

- The cross-sectional dimensions of the duct are $610 \times 610 \text{ mm}$ ($24 \times 24 \text{ in.}$).
- The HEPA filter bank, transition, aerosol injection tube, mixing orifice, perforated diffusion plate, upstream sampling probe, and main flow measurement nozzle are designed and installed according to Section 4.2.
- The test filter does not extend beyond the length of the duct.
- Test environmental conditions meet Section 4.2.3.

The conditioning duct can be operated in a positive or a negative pressure mode.

J4. SUBSECTION TO BE USED WITH SECTION 5.1

J4.1 If a separate duct is used for the conditioning step (see Section J3.3) then velocity uniformity (see Section 5.2) shall be performed on that duct.

J5. SUBSECTION TO BE USED WITH SECTION 5, "APPARATUS QUALIFICATION TESTING"

J5.1 Uniformity of the Conditioning Aerosol Concentration

J5.1.1 The uniformity of the conditioning aerosol concentration across the duct cross section shall be determined by a nine-point traverse in the 610 × 610 mm (24 × 24 in.) duct immediately upstream of the device section (i.e., at the location of the upstream sample probe) using the grid points shown in Figure 5-1. The traverse shall be made by either (a) installing nine sample probes of identical curvature, diameter, and inlet nozzle diameter but of variable vertical length or (b) repositioning a single probe.

J5.1.2 The conditioning aerosol generation system shall be operated in the same manner as intended for conditioning of test filters.

J5.1.3 The aerosol concentration measurements shall be made with a CPC meeting the specifications of Section J3.1. A one-minute average concentration shall be recorded at each grid point. The average shall be based on at least ten readings

taken at equal intervals during the one-minute period. After sampling all nine points, the traverse shall then be repeated four more times to provide a total of five samples from each point. These five values for each point shall then be averaged. The traverse measurements shall be performed at airflow rates of 0.22, 0.93, and 1.4 m³/s (472, 1970, and 2990 cfm).

J5.2 The CV of the corresponding nine grid point particle concentrations shall be less than 15% for each airflow rate.

J5.2.1 Ratio of Small to Large Particles in the Conditioning Aerosol. With the conditioning aerosol generator operating as it would for conditioning operation during a standard test, the in-duct aerosol concentration shall be measured with the CPC and with the particle counter used for PSE testing. The CPC sample inlet shall be located within 100 mm (4 in.) of the OPS inlet, and they can share the same inlet. The ratio of the CPC concentration to the concentration of particles >0.3 μm (measured by the PSE particle counter and consisting of all particles measured between 0.3 and 10 μm) shall be >20,000.

Note: The units of concentration must be the same to calculate the correct ratio. Typically the particle counter output is in units of particles/m³ and the CPC output is in units of particles/cm³.

J6. SUBSECTION TO BE USED WITH TABLE 5-1, SYSTEM QUALIFICATION MEASUREMENT REQUIREMENTS OF THE STANDARD

Parameter	Requirement
Ratio of the CPC concentration to the concentration of particles >0.3 μm (measured by the PSE particle counter)	Ratio > 20,000
Conditioning aerosol uniformity: based on traverse measurements made over a 9-point equal-area grid at each test airflow rate	CV < 15%
Conditioning aerosol in-duct aerosol concentration	<1 × 10 ⁶ cm ⁻³ or less than the concentration limit of the CPC, whichever is smaller

J7. SUBSECTION TO BE USED WITH TABLE 5-2, APPARATUS MAINTENANCE SCHEDULE OF THE STANDARD

Maintenance Item	Incorporated into Each Test	Monthly	Biannually	After Change that May Alter Performance	Comment
Drain, rinse, and refill the Laskin generator with fresh 0.1% KCl solution					Daily
Ratio of the CPC concentration to the concentration of particles >0.3 μm	×				
Conditioning aerosol uniformity			×	×	
Conditioning aerosol concentration	×				

J8. SUBSECTION TO BE USED WITH SECTION 6, "TEST MATERIALS"

J8.1 Conditioning Aerosol. The conditioning aerosol shall be solid-phase potassium chloride (KCl) particles generated from an aqueous solution. The solution shall be prepared by dissolving reagent-grade KCl in distilled or filtered deionized water at a proportion of 1.00 g of KCl per 1.00 L of water.

J9. SUBSECTION TO BE USED WITH SECTION 8.2, "TEST SEQUENCE"

J9.1 Test Sequence. The sequence of tests on the device shall be as follows:

- a. Resistance vs. airflow rate of the clean device at various airflow rates as prescribed in Section 9.
- b. PSE of the clean device as prescribed in Section 10.
- c. PSE of the device, as prescribed in Section 10, after conditioning per this appendix.
- d. PSE of the device, as prescribed in Section 10, when incrementally loaded with synthetic dust, with the exception of the 30 g conditioning load (see Section 10.7.1.2.b).

J10. CONDITIONING PROCEDURE (USE THIS PROCEDURE INSTEAD OF SECTION 10.7.1.2.B OF THE STANDARD)

J10.1 After the initial efficiency test is completed, the filter shall be exposed to the conditioning aerosol. The duct airflow rate used during the conditioning step will be the same as is used during the dust-loading and particle size efficiency testing. Note that all filters tested according to this standard must be exposed to the same conditioning aerosol procedure, regardless of the specific materials, construction details, or other variables.

J10.2 Prior to conditioning, all internal surfaces of the Laskin generator shall be rinsed with distilled or filtered deionized water and then filled with KCl solution, as specified in Section J8.1.

J10.3 Record the background concentration using the CPC upstream of the test device with the duct airflow rate set to the same value used during testing.

J10.4 The measured in-duct conditioning aerosol concentration shall not exceed 1.0×10^6 particles/cm³.

J10.5 Conditioning shall be performed in incremental steps with a PSE taken after each increment. The minimum incremental conditioning step shall be a CT of 6.4×10^7 particles/cm³·min. Conditioning is stopped when either (a) the current measurement shows no further significant drop in efficiency or (b) the cumulative CT exposure of the filter reaches a CT of 1.2×10^9 particles/cm³·min. A "significant drop" is a drop in efficiency of at least two percentage points in two or more adjacent particle size ranges relative to the minimum efficiencies in those ranges measured in any of the previous steps.

Note: Filters with large media area (typical of 300 mm or 12 in. filters and bag filters) may require cumulative conditioning CTs up to the maximum level of 1.2×10^9 particles/cm³·min. The test laboratory should select an incremental conditioning step size consistent with this expectation and avoid relatively

small conditioning increments that may underchallenge the filter.

J10.6 Periodically during conditioning, the in-duct concentration of the conditioning aerosol shall be measured and recorded. The measurement interval shall be such that a minimum of three measurements are obtained during each conditioning interval.

J10.7 Whenever the determined correlation ratio is (see Section 10.3), it is recommended that the ratio of the concentration of small to large particles be measured. This ratio must be evaluated a minimum of two times during the conditioning procedure, once at the beginning of the conditioning and once at the end of the conditioning. The small-particle concentration is that obtained from the CPC. The large-particle concentration is that obtained from the PSE particle counter and is the concentration of all particles >0.3 μm. The ratio of the concentrations must be >20,000.

J10.8 To prevent deliquescence of the KCl during conditioning, relative humidity must be maintained below 50% in the test duct at all times during the test. Also, the airflow from all particle generators must result in relative humidity ≤ 50% in the air in the rig at all times after mixing has occurred. If the filter is removed from the test duct for any reason during the test, it must be stored in an environment with relative humidity less than 65%.

J11. SUBSECTION TO BE USED WITH SECTION 11.2

J11.1 Conditioning

- a. The background concentration (particles/cm³)
- b. The average conditioning aerosol concentration (particles/cm³)
- c. The cumulative conditioning duration (minutes)
- d. The cumulative conditioning CT (particles/cm³·min)
- e. The PSE following each conditioning increment
- f. Dust holding capacity DHC-A (grams)

J11.2 Minimum Efficiency Reporting Value (MERV-A) According to Appendix J

- a. The average of the minimum PSE of the four size ranges from 0.30 to 1.0 μm (E_{1-A})
- b. The average of the minimum PSE of the four size ranges from 1.0 to 3.0 μm (E_{2-A})
- c. The average of the minimum PSE of the four size ranges from 3.0 to 10.0 μm (E_{3-A})
- d. MERV-A for the device

J11.3 Minimum Efficiency Reporting Value (MERV-A) According to Appendix J for Air Cleaners

J11.3.1 The minimum efficiency reporting value (MERV-A) for an air cleaner shall be based on three composite average PSE points developed from a test at a manufacturer's specified airflow rate selected in accordance with Section 8.1. Dust loading shall follow the procedure outlined in Section 10.7 except substituting Section J10 of this appendix for Section 10.7.1.2(b) of the standard. The results of the tests shall be reported in accordance with Sections 10.8.1 and 10.8.2. The four data points from the Section 10.8.2 composite curve in each of the three size range groups from

Table J-1 shall be averaged and the resultant three average minimum PSEs (E_1 -A, E_2 -A, and E_3 -A) shall be reported.

J11.3.2 With this appendix, the minimum final resistance for an air cleaner shall always be the same as or greater than twice the initial resistance.

J11.3.3 With this appendix, the minimum efficiency reporting value in the specified size ranges for reporting purposes shall be in accordance with Table J-2.

J11.3.4 The reporting designator shall be a combination of the air cleaner's MERV-A and the test airflow rate (e.g., MERV-A 10-A at 0.93 indicates that the air cleaner has a

Table J-1 Size Range Groups

Average Minimum PSE Designator	Corresponding Size Range Group, μm
E_1 -A	0.30 to 1.0
E_2 -A	1.0 to 3.0
E_3 -A	3.0 to 10

Table J-2 KCI Conditioned Per Appendix J Minimum Efficiency Reporting Value (MERV-A) Parameters

Standard 52.2 Minimum Efficiency Reporting Value (MERV-A)	Composite Average Particle Size Efficiency, % in Size Range, μm			Average Arrestance, %
	Range 1 (0.30 to 1.0 μm)	Range 2 (1.0 to 3.0 μm)	Range 3 (3.0 to 10.0 μm)	
1-A	N/A	N/A	E_3 -A < 20	$A_{avg} < 65$
2-A	N/A	N/A	E_3 -A < 20	$65 \leq A_{avg}$
3-A	N/A	N/A	E_3 -A < 20	$70 \leq A_{avg}$
4-A	N/A	N/A	E_3 -A < 20	$75 \leq A_{avg}$
5-A	N/A	N/A	$20 \leq E_3$ -A	N/A
6-A	N/A	N/A	$35 \leq E_3$ -A	N/A
7-A	N/A	N/A	$50 \leq E_3$ -A	N/A
8-A	N/A	$20 \leq E_2$ -A	$70 \leq E_3$ -A	N/A
9-A	N/A	$35 \leq E_2$ -A	$75 \leq E_3$ -A	N/A
10-A	N/A	$50 \leq E_2$ -A	$80 \leq E_3$ -A	N/A
11-A	$20 \leq E_1$ -A	$65 \leq E_2$ -A	$85 \leq E_3$ -A	N/A
12-A	$35 \leq E_1$ -A	$80 \leq E_2$ -A	$90 \leq E_3$ -A	N/A
13-A	$50 \leq E_1$ -A	$85 \leq E_2$ -A	$90 \leq E_3$ -A	N/A
14-A	$75 \leq E_1$ -A	$90 \leq E_2$ -A	$95 \leq E_3$ -A	N/A
15-A	$85 \leq E_1$ -A	$90 \leq E_2$ -A	$95 \leq E_3$ -A	N/A
16-A	$95 \leq E_1$ -A	$95 \leq E_2$ -A	$95 \leq E_3$ -A	N/A

ASHRAE Standard 52.2 Air-Cleaner Performance Report Summary with Optional Conditioning Procedure According to Appendix J

(This report applies to the tested device only)

Laboratory Data

Report number _____ Test number _____ Date _____
Test laboratory _____
Operator _____ Supervisor _____
Particle counters: Brand _____ Model _____

Device Manufacturer's Data

Manufacturer _____ Product name _____
Model _____ Test requested by _____
Sample obtained from _____
Catalog rating: Airflow rate _____ Initial pressure drop _____
Specified test conditions: Airflow _____ Final pressure drop _____
Face velocity _____

Device Description

Dimensions: Height _____ Width _____ Depth _____
Generic name _____ Media type _____
Effective media area _____ Media color _____
Amount and type of adhesive (Tackifier) _____
Other attributes _____

Test Conditions

Airflow rate _____ Temperature _____ Relative Humidity _____
Test aerosol type _____ Final pressure drop _____ Face velocity _____
Duct configuration (one or two ducts used): _____
Remarks _____

Conditioning Parameters

Background concentration (particles/cm³) _____
Average cond aerosol concentration (particles/cm³) _____
Cumulative conditioning duration (minutes) _____
Is filter continuously conditioned in the same duct? _____
Cumulative conditioning CT (particles/cm³ min) _____
PSE following each conditioning increment _____

Resistance Test Results

Initial resistance _____ Final resistance _____

KCI Conditioned Minimum Efficiency Reporting Data (According to Appendix J)

Composite average efficiencies: E_{1-A} _____ E_{2-A} _____ E_{3-A} _____
Air-cleaner average arrestance: A_{avg-A} _____
Dust holding capacity: DHC-A _____
Minimum efficiency reporting value: MERV-A _____

(This appendix is not part of this standard. It is merely informative and does not contain requirements necessary for conformance to the standard. It has not been processed according to the ANSI requirements for a standard and has not been subject to public review or a consensus process. Unresolved objectors on informative material are not offered the right to appeal at ASHRAE or ANSI.)

INFORMATIVE APPENDIX K OPTIONAL METHOD OF TESTING TWO AIR FILTERS ARRANGED IN SERIES IN A SYSTEM TO EVALUATE PARTICLE REMOVAL, DUST LOADING, AND PRESSURE DROP INCREASE THAT MIGHT BE REALIZED IN FIELD APPLICATIONS

K1. PURPOSE OF OPTIONAL TEST

This appendix is to be used to evaluate the performance of two air-cleaning devices arranged in airflow series. In this appendix the first filter serves as a prefilter and the second filter serves as the final filter. It is possible for both filters to be the same filter. The test protocol is based on ASHRAE Standard 52.2. Equipment and procedures specified in Standard 52.2 are used to conduct this test.

This procedure measures the ability of the prefilter and final filter to remove dust as the filters become loaded with a standardized loading dust. The loading dust is fed at intervals to simulate accumulation of particles during filter service life. Resistances of the individual filters are monitored separately. The prefilter is replaced with a new prefilter whenever its preselected final resistance is reached. This process is continued until the preselected resistance of the final filter is reached. After the initial particle size efficiency (PSE) test, the resistance of the final filter is used to position the five additional PSE tests.

K2. DEFINITIONS AND ACRONYMS

K2.1 Definitions to be used in addition to those listed in Section 3 of Standard 52.2 are as follows.

dust-holding capacity final filter (DHCF): the total weight of the synthetic loading dust captured by the second-in-series air-cleaning device over the dust-loading steps until the final filter reaches its predetermined final resistance.

dust-holding capacity prefilter #1 (DHCPF1): the total weight of the synthetic loading dust captured by the first-in-series air-cleaning device over the dust-loading steps until the prefilter reaches its predetermined final resistance. Each additional prefilter designation would be the next incremental numerical digit, i.e., DHCPF2, DHCPF3.

final filter: the second filter in the two-stage system.

prefilter: the first filter in the two-stage system.

total system dust-holding capacity (TDHC): the sum total weight of the synthetic loading of all prefilters and the final filter.

K3. SUBSECTION TO BE USED WITH SECTION 7.2, "PREPARATION OF THE SAMPLES"

K3.1 The devices shall be installed in the duct with a space between the filters of 203 to 914 mm (8 to 36 in.).

K3.2 Distance between devices should be documented in the test report.

K4. SUBSECTION TO BE USED WITH SECTION 8.2, "TEST PROCEDURES"

K4.1 Test Sequence. The sequence of tests on the two-stage system shall be as follows:

- Resistance vs. airflow rate of the prefilter at various airflow rates as prescribed in Section 9.
- Resistance vs. airflow rate of the final filter at various airflow rates as prescribed in Section 9.
- PSE prescribed in Section 10.7.1.2(b) to be replaced with the following: *The prefilter after an initial conditioning step with a dust loading of 30 g or an increase of 10 Pa (0.04 in. of water) pressure drop across the prefilter, whichever comes first.*
- PSE prescribed in Section 10.7.1.2(c) to be replaced with the following: *After the dust-loading increments have achieved an airflow resistance increase of one-quarter, one-half, and three-quarters of the difference between the beginning and the prescribed end-point limit of airflow resistance for the final filter.*
- PSE prescribed in Section 10.7.1.2(d) to be replaced with the following: *After the dust increment that loads the final filter to its prescribed end point resistance limit.*

K5. SUBSECTION TO BE USED WITH SECTION 9, "MEASUREMENT OF RESISTANCE VERSUS AIRFLOW"

K5.1 Measure, record, and report the resistance of the prefilter, the final filter, and the system at a minimum of four airflow rates: 50%, 75%, 100%, and 125% of test airflow rate. Resistance shall be measured between the static taps.

K6. SUBSECTION TO BE USED WITH SECTION 10.7.2, "DUST LOADING PROCEDURES"

K6.1 When the prefilter reaches its prescribed final resistance, it shall be replaced by a clean prefilter. The replacement filter shall be identical to the one being replaced.

K6.2 Repeat the prefilter replacement process until the final filter reaches its final resistance.

K6.3 Weigh each prefilter to the nearest 0.1 g before and after use to determine dust weight gain (DWG).

K6.4 Weigh final filter to the nearest 0.1 g before and after use to determine DWG.

K7. SUBSECTION TO BE USED WITH SECTION 10.8, "REPORTING RESULTS OF LOADING TESTS"

K7.1 Results of loading tests shall be reported in the form of PSE curves for the two-stage system:

- a. clean;
- b. after each incremental dust loading of the final filter, a total of four curves; and
- c. at final filters final loading point.

K8. SUBSECTION TO BE USED WITH SECTION 11, "REPORTING RESULTS"

K8.1 The summary section of the performance report shall include the following information.

- a. Name and location of the test laboratory
- b. Date of the test
- c. Test operator's names
- d. Brand and model number of the particle counting and sizing devices
- e. Air-cleaner manufacturer's name (or name of the marketing organization if different from the manufacturer)
- f. How the sample was obtained
- g. Description of each test air cleaner, including the following:
 - 1. Brand and model number
 - 2. Physical description of construction (e.g., extended surface—number of pockets or number of pleats; pleated panel—number and depth of pleats)
 - 3. Face dimensions and depth
 - 4. For fiber media air cleaners
 - i. Type and color of media
 - ii. Effective media area
 - iii. Type and amount of dust adhesive if known
 - iv. Electrostatic charge if known
 - 5. Any other pertinent descriptive attributes
- h. Operating data as stated by the manufacturer
 - 1. Test conditions for reporting purposes: airflow rate
 - 2. Final resistances for both air cleaners

- 3. Any other operating data furnished
- i. Test data
 - 1. Test air temperature and relative humidity
 - 2. Airflow rate
 - 3. Type of test aerosol
 - 4. Distance between the two filters from back edge of prefilter to front edge of final filter
- j. Results of resistance testing
 - 1. Initial resistance of prefilter
 - 2. Initial resistance of final filter
 - 3. Initial resistance of system
 - 4. Final resistance of system
 - 5. Number of times the prefilter is changed
- k. Performance curves
 - 1. A curve in Figure 11-1b format of the prefilter, final filter, and system resistance when clean vs. airflow rates from 50% to 125% of test flow
 - 2. A curve in Figure 11-1c format of PSE for the clean system and for the system at each of the five loading stages of the final filter
 - 3. A minimum PSE composite curve in Figure 11-1c format whose data points are the lowest PSEs from the six measurements in each particle size range from the curves of test results for the system
 - 4. Resistance vs. synthetic loading dust fed during the entire test sequence for prefilter, final filter, and system
- l. Average ASHRAE dust arrestance
- m. Dust holding capacity (DHC)
 - 1. A DHC for each prefilter
 - 2. A DHC for the final filter
 - 3. A DHC for the entire test cycle

NOTICE

INSTRUCTIONS FOR SUBMITTING A PROPOSED CHANGE TO THIS STANDARD UNDER CONTINUOUS MAINTENANCE

This standard is maintained under continuous maintenance procedures by a Standing Standard Project Committee (SSPC) for which the Standards Committee has established a documented program for regular publication of addenda or revisions, including procedures for timely, documented, consensus action on requests for change to any part of the standard. SSPC consideration will be given to proposed changes within 13 months of receipt by the Senior Manager of Standards (SMOS).

Proposed changes must be submitted to the SMOS in the latest published format available from the SMOS. However, the SMOS may accept proposed changes in an earlier published format if the SMOS concludes that the differences are immaterial to the proposed change submittal. If the SMOS concludes that a current form must be utilized, the proposer may be given up to 20 additional days to resubmit the proposed changes in the current format.

ELECTRONIC PREPARATION/SUBMISSION OF FORM FOR PROPOSING CHANGES

An electronic version of each change, which must comply with the instructions in the Notice and the Form, is the preferred form of submittal to ASHRAE Headquarters at the address shown below. The electronic format facilitates both paper-based and computer-based processing. Submittal in paper form is acceptable. The following instructions apply to change proposals submitted in electronic form.

Use the appropriate file format for your word processor and save the file in either a recent version of Microsoft Word (preferred) or another commonly used word-processing program. Please save each change proposal file with a different name (for example, "prop01.doc," "prop02.doc," etc.). If supplemental background documents to support changes submitted are included, it is preferred that they also be in electronic form as word-processed or scanned documents.

For files submitted attached to an e-mail, ASHRAE will accept an electronic signature (as a picture; *.tif, or *.wpg) on the change submittal form as equivalent to the signature required on the change submittal form to convey non-exclusive copyright.

Submit an e-mail containing the change proposal files to:
change.proposal@ashrae.org

Alternatively, mail paper versions to:
ASHRAE
Senior Manager of Standards
1791 Tullie Circle, NE
Atlanta, GA 30329-2305

Or fax them to:
Attn: Senior Manager of Standards
678-539-2129

The form and instructions for electronic submittal may be obtained from the Standards section of ASHRAE's Home Page, www.ashrae.org, or by contacting a Standards Secretary via phone (404-636-8400), fax (678-539-2129), e-mail (standards.section@ashrae.org), or mail (1791 Tullie Circle, NE, Atlanta, GA 30329-2305).



FORM FOR SUBMITTAL OF PROPOSED CHANGE TO AN ASHRAE STANDARD UNDER CONTINUOUS MAINTENANCE

NOTE: Use a separate form for each comment. Submittals (Microsoft Word preferred) may be attached to e-mail (preferred), or submitted in paper by mail or fax to ASHRAE, Senior Manager of Standards, 1791 Tullie Circle, NE, Atlanta, GA 30329-2305. E-mail: change.proposal@ashrae.org. Fax: +1-678-539-2129.

1. Submitter:

Affiliation:

Address:

City:

State:

Zip:

Country:

Telephone:

Fax:

E-Mail:

I hereby grant ASHRAE the non-exclusive royalty rights, including non-exclusive rights in copyright, in my proposals. I understand that I acquire no rights in publication of the standard in which my proposals in this or other analogous form is used. I hereby attest that I have the authority and am empowered to grant this copyright release.

Submitter's signature: _____ Date: _____

All electronic submittals must have the following statement completed:

I (*insert name*) _____, through this electronic signature, hereby grant ASHRAE the non-exclusive royalty rights, including non-exclusive rights in copyright, in my proposals. I understand that I acquire no rights in publication of the standard in which my proposals in this or other analogous form is used. I hereby attest that I have the authority and am empowered to grant this copyright release.

2. Number and year of standard:

3. Page number and clause (section), subclause, or paragraph number:

4. I propose to: Change to read as follows Delete and substitute as follows
(*check one*) Add new text as follows Delete without substitution

Use underscores to show material to be added (added) and strike through material to be deleted (~~deleted~~). Use additional pages if needed.

5. Proposed change:

6. Reason and substantiation:

7. Will the proposed change increase the cost of engineering or construction? If yes, provide a brief explanation as to why the increase is justified.

Check if additional pages are attached. Number of additional pages: _____

Check if attachments or referenced materials cited in this proposal accompany this proposed change. Please verify that all attachments and references are relevant, current, and clearly labeled to avoid processing and review delays. *Please list your attachments here:*

POLICY STATEMENT DEFINING ASHRAE'S CONCERN FOR THE ENVIRONMENTAL IMPACT OF ITS ACTIVITIES

ASHRAE is concerned with the impact of its members' activities on both the indoor and outdoor environment. ASHRAE's members will strive to minimize any possible deleterious effect on the indoor and outdoor environment of the systems and components in their responsibility while maximizing the beneficial effects these systems provide, consistent with accepted Standards and the practical state of the art.

ASHRAE's short-range goal is to ensure that the systems and components within its scope do not impact the indoor and outdoor environment to a greater extent than specified by the Standards and Guidelines as established by itself and other responsible bodies.

As an ongoing goal, ASHRAE will, through its Standards Committee and extensive Technical Committee structure, continue to generate up-to-date Standards and Guidelines where appropriate and adopt, recommend, and promote those new and revised Standards developed by other responsible organizations.

Through its *Handbook*, appropriate chapters will contain up-to-date Standards and design considerations as the material is systematically revised.

ASHRAE will take the lead with respect to dissemination of environmental information of its primary interest and will seek out and disseminate information from other responsible organizations that is pertinent, as guides to updating Standards and Guidelines.

The effects of the design and selection of equipment and systems will be considered within the scope of the system's intended use and expected misuse. The disposal of hazardous materials, if any, will also be considered.

ASHRAE's primary concern for environmental impact will be at the site where equipment within ASHRAE's scope operates. However, energy source selection and the possible environmental impact due to the energy source and energy transportation will be considered where possible. Recommendations concerning energy source selection should be made by its members.

ASHRAE · 1791 Tullie Circle NE · Atlanta, GA 30329 · www.ashrae.org

About ASHRAE

ASHRAE, founded in 1894, is a global society advancing human well-being through sustainable technology for the built environment. The Society and its members focus on building systems, energy efficiency, indoor air quality, refrigeration, and sustainability. Through research, Standards writing, publishing, certification and continuing education, ASHRAE shapes tomorrow's built environment today.

For more information or to become a member of ASHRAE, visit www.ashrae.org.

To stay current with this and other ASHRAE Standards and Guidelines, visit www.ashrae.org/standards.

Visit the ASHRAE Bookstore

ASHRAE offers its Standards and Guidelines in print, as immediately downloadable PDFs, on CD-ROM, and via ASHRAE Digital Collections, which provides online access with automatic updates as well as historical versions of publications. Selected Standards and Guidelines are also offered in redline versions that indicate the changes made between the active Standard or Guideline and its previous version. For more information, visit the Standards and Guidelines section of the ASHRAE Bookstore at www.ashrae.org/bookstore.

IMPORTANT NOTICES ABOUT THIS STANDARD

To ensure that you have all of the approved addenda, errata, and interpretations for this Standard, visit www.ashrae.org/standards to download them free of charge.

Addenda, errata, and interpretations for ASHRAE Standards and Guidelines are no longer distributed with copies of the Standards and Guidelines. ASHRAE provides these addenda, errata, and interpretations only in electronic form to promote more sustainable use of resources.